

TRENCH BACKFILL REQUIREMENTS:

1. PROPOSED STREETS – REFER TO DETAIL TB-1 OF SECTION 31 FOR BACKFILL REQUIREMENTS ABOVE THE PIPE ZONE.
2. EXISTING STREETS – REFER TO DETAILS TB-1 AND TB-3, TB-3a OF SECTION 31 FOR BACKFILL REQUIREMENTS ABOVE THE PIPE ZONE.

Richard D. Plecker
 RICHARD PLECKER
 ENVIRONMENTAL UTILITIES DIRECTOR

 ENVIRONMENTAL UTILITIES DEPARTMENT	WATER MAIN TRENCH AND BACKFILL	
	SCALE: NONE REVISED: OCTOBER 2020 DRAWN BY: R. VAN NESS APPROVED BY: RICHARD PLECKER	W-1

NOTES:

- BACKFILL SHALL BE MECHANICALLY CONSOLIDATED OR SHOVEL SLICED UNDER THE HAUNCHES OF THE PIPE.
- IN ROCKY OR UNYIELDING SOIL, THE TRENCH SHALL BE EXCAVATED A MINIMUM OF 12" BELOW THE PIPE AND THE TRENCH WIDTH SHALL BE INCREASED BY 12".
- ONE 12" WIDE STRIP OF BACKFILL TAPE SHALL BE USED FOR EVERY 12" PIPE DIAMETER OR FRACTION THERE OF.

NOTES:

NO WATER SHALL BE DRAWN THROUGH THE BACKFLOW DEVICE UNTIL IT HAS BEEN TESTED BY THE ENVIRONMENTAL UTILITIES DEPT.

THE BACKFLOW DEVICE SHALL BE INSULATED WITH A CITY APPROVED FREEZE PROTECTION BAG

FITTINGS SHALL BE FLANGE BY FLANGE OR RESTRAINED.

BURIED NUTS AND BOLTS, AND BARE METAL SHALL BE COATED WITH BITUMINOUS MATERIAL.

PIPE AND FITTINGS SHALL BE DUCTILE IRON.

BURIED PIPE AND FITTINGS SHALL BE WRAPPED AND SEALED WITH 8 MIL POLYETHYLENE AND VINYL TAPE.

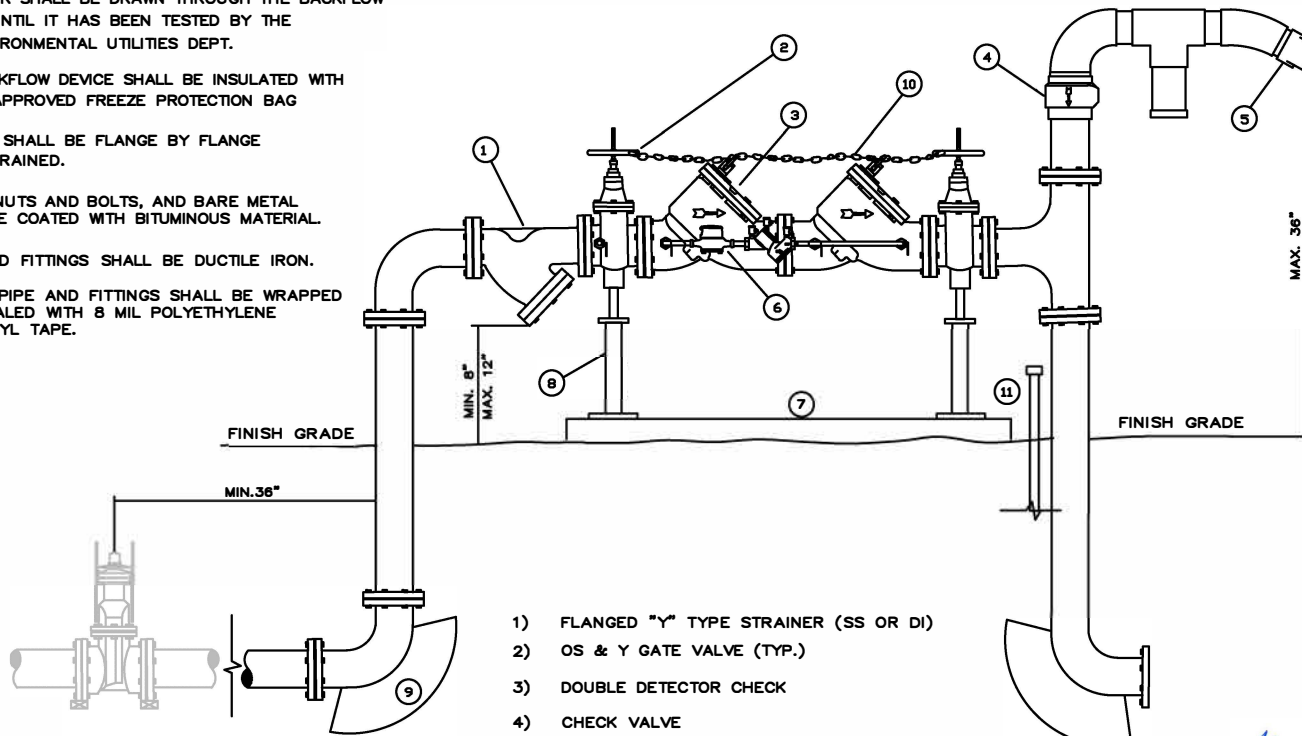

SEE DETAILS
W-15 AND W-16
FOR VALVE

- 1) FLANGED "Y" TYPE STRAINER (SS OR DI)
- 2) OS & Y GATE VALVE (TYP.)
- 3) DOUBLE DETECTOR CHECK
- 4) CHECK VALVE
- 5) SIAMESE 45 DEGREE FDC WITH END CAPS
- 6) WATER METER
- 7) 3 1/2" THICK REINFORCED CONCRETE SLAB. WITH #4 REBAR 12" ON CENTER
- 8) SUPPORTS 2-TYP. SHALL BE BOLTED DOWN WITH A MINIMUM OF TWO BOLTS EACH
- 9) THRUST BLOCK (TYP.)
- 10) 1/4" NON CASE HARDENED CHAIN WITH BREAKAWAY LOCK BETWEEN VALVES.
- 11) VALVE TAMPER SWITCH CONDUIT TO BUILDING FIRE CONTROL ROOM

Richard D. Plecker

RICHARD PLECKER
ENVIRONMENTAL UTILITIES DIRECTOR

	ENVIRONMENTAL UTILITIES DEPARTMENT
	FIRE PROTECTION ASSEMBLY

SCALE: NONE
 REVISED: JANUARY 2017
 DRAWN BY: R. VAN NESS
 APPROVED BY: RICHARD PLECKER

W-2

NOTES:

NO WATER SHALL BE DRAWN THROUGH THE BACKFLOW DEVICE UNTIL IT HAS BEEN TESTED BY THE ENVIRONMENTAL UTILITIES DEPT.

THE BACKFLOW DEVICE SHALL BE INSULATED WITH A CITY APPROVED FREEZE PROTECTION BAG

FITTINGS SHALL BE FLANGE BY FLANGE OR RESTRAINED.

BURIED NUTS AND BOLTS, AND BARE METAL SHALL BE COATED WITH BITUMINOUS MATERIAL.

PIPE AND FITTINGS SHALL BE DUCTILE IRON.

BURIED PIPE AND FITTINGS SHALL BE WRAPPED AND SEALED WITH 8 MIL POLYETHYLENE AND VINYL TAPE.

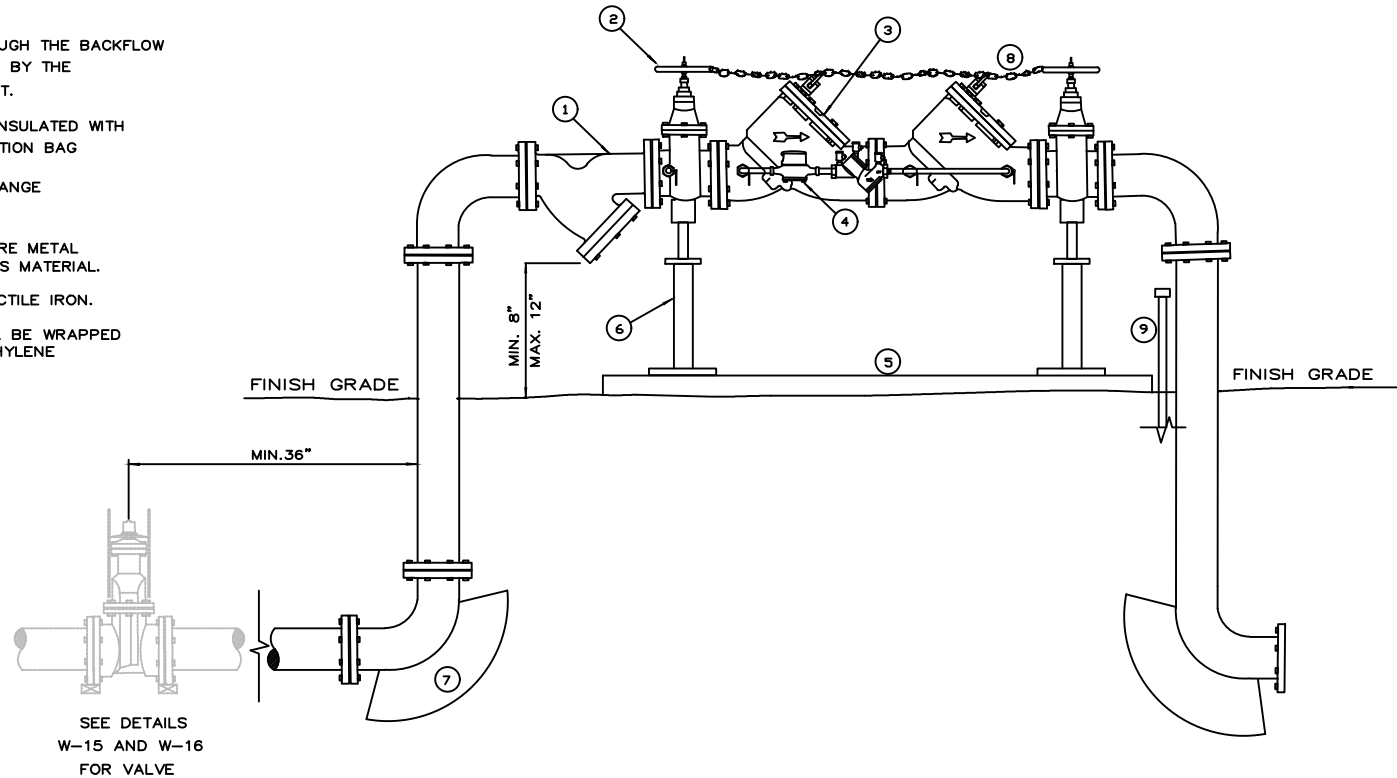

Richard D. Plecker
 RICHARD PLECKER
 ENVIRONMENTAL UTILITIES DIRECTOR

- 1) FLANGED "Y" TYPE STRAINER (SS OR DI)
- 2) OS & Y GATE VALVE (TYP.)
- 3) DOUBLE DETECTOR CHECK
- 4) WATER METER
- 5) 3 1/2" THICK REINFORCED CONCRETE SLAB W/#4 REBAR 12" ON CENTER.
- 6) SUPPORTS 2-TYP. SHALL BE BOLTED DOWN WITH A MINIMUM OF TWO BOLTS EACH
- 7) THRUST BLOCK (TYP.)
- 8) 1/4" NON CASE HARDENED CHAIN WITH BREAKAWAY LOCK BETWEEN VALVES.
- 9) VALVE TAMPER SWITCH CONDUIT TO BUILDING FIRE CONTROL ROOM.

	ENVIRONMENTAL UTILITIES DEPARTMENT
	ONSITE FIRE PROTECTION
SCALE: NONE REVISED: JANUARY 2019 DRAWN BY: R. VAN NESS APPROVED BY: RICHARD PLECKER	
W-3	

NOTE:

1. CONCRETE COLLAR MAY BE PLACED FLUSH TO FINISHED SURFACE WITH MEDIUM BROOM FINISH PERPENDICULAR TO VEHICLE TRAVEL DIRECTION
2. REFERENCE CITY DESIGN STANDARD 8-13.E

VALVE BOX W/LID
MARKED "B.O."
INSTALL PER W-16.

WHERE APPLICABLE
(SIDEWALK)

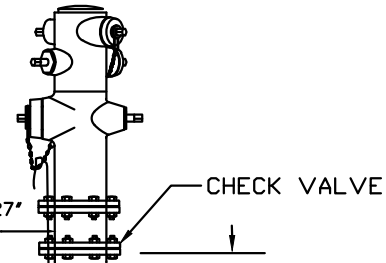

F.G.

2 1/2" MIN.
4" MAX.

INSTALL CONCRETE THRUST COLLAR 8" THICK
AND 30" X 30" SQUARE

MAINS: 36" MINIMUM COVER
TRANSMISSION MAINS: 48" MINIMUM COVER

Richard D. Plecker

RICHARD PLECKER
ENVIRONMENTAL UTILITIES DIRECTOR

TRACING WIRE

6" Ø FIRE HYDRANT BURY
(See Detail W-13)

FLANGED
GATE VALVE

CITY MAIN
WITH APPROVED
RESTRAINED
JOINTS

REDUCER

INSULATING FLANGE SEE DETAIL
W-19, W-20, AND W-21

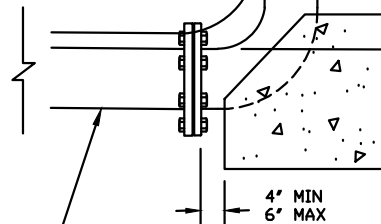

4" MIN
6" MAX

6" Ø FLANGED DIP AND
FITTINGS, SEE PLANS
FOR LENGTH,
ORIENTATION AND
LOCATION



ENVIRONMENTAL UTILITIES
DEPARTMENT

**DEAD-END HYDRANT
ASSEMBLY**

SCALE: NONE
REVISED: JANUARY 2023
DRAWN BY: J THOMPSON
APPROVED BY: RICHARD PLECKER

W-4

CURB STAMPED "W"
AT SERVICE LOCATION

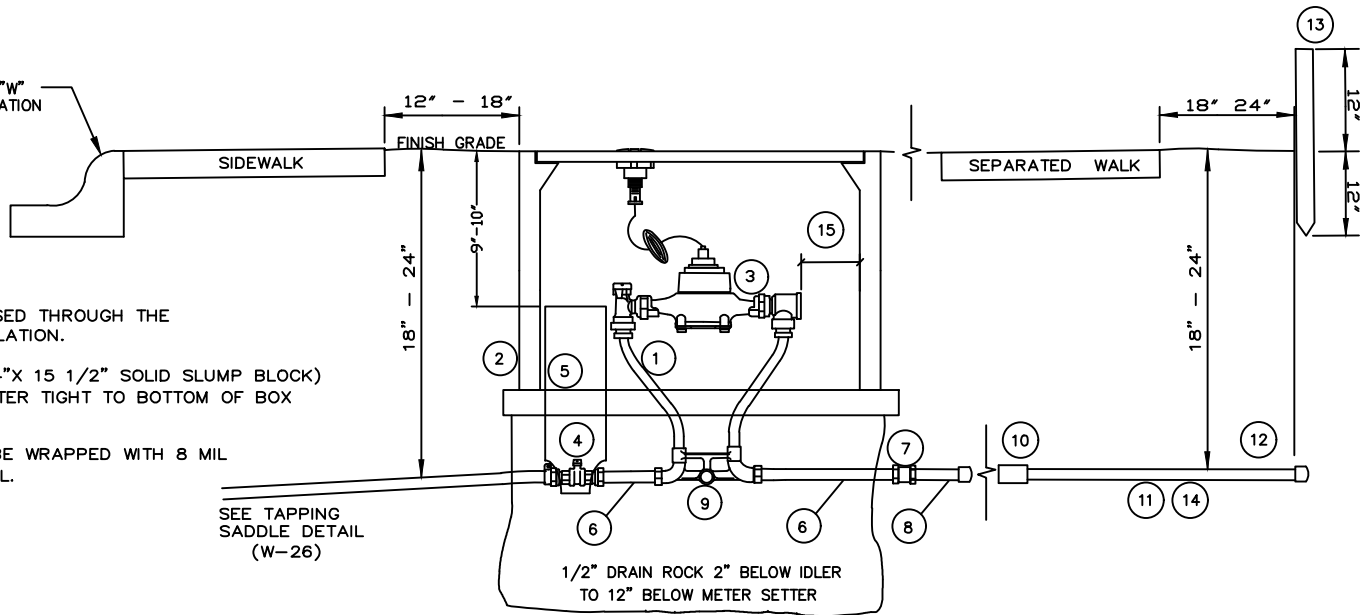

NOTES:

WATER METERS SHALL BE PURCHASED THROUGH THE CITY. PURCHASE INCLUDES INSTALLATION.

INSTALL CONCRETE BLOCKING (4"x4"x 15 1/2" SOLID SLUMP BLOCK) UNDER ENTIRE UTILITY BOX PERIMETER TIGHT TO BOTTOM OF BOX NO GAPS ALLOWED

BURIED PIPE AND FITTINGS SHALL BE WRAPPED WITH 8 MIL POLYETHYLENE OR APPROVED EQUAL.

SEE TAPPING
SADDLE DETAIL
(W-26)

1/2" DRAIN ROCK 2" BELOW IDLER
TO 12" BELOW METER SETTER

- 1) METER SETTER WITH IDLER
- 2)* N-30 UTILITY BOX WITH FL 30 METER LID FOR 1" SERVICE
- 3) WATER METER (PURCHASED THROUGH CITY)
- 4) CURB STOP (COMPRESSION X FIPT)
- 5) 4" DIA. BLUE SCHEDULE 40 RISER (NOTCHED OVER PIPE AT BASE)
- 6) 4" METER SPUD
- 7) BRASS COUPLING (FIPT X FIPT)
- 8) 18" BRASS NIPPLE WITH END CAP (FOR ATTACHED SIDEWALK)
- 9) SCH. 40 PVC THROUGH PIPE EYE
- 10) BRASS-PVC ADAPTER
- 11) 1 1/2" PVC
- 12) PVC END CAP
- 13) 2"x2" RDWD. STAKE PAINTED BLUE
- 14) AS AN OPTION, CONTRACTOR MAY INSTALL A 3" SCH 40 SLEEVE PRIOR TO INSTALLATION OF 1-1/2" PVC.
- 15) SETTERS W/VERTICAL CHECK, PROVIDE 1" GAP MIN. THE SETTERS W/HORIZONTAL CHECK, PROVIDE 2" GAP MIN.(NOTCH THE TOP OF THE 4"SCHEDULE 40 RISER TO ACHIEVE 2"GAP).

* IF LOCATED IN THE DRIVEWAY USE A B1324 BOX W/STEEL CHECKER COVER #B1324-51JH OR APPROVED EQUAL.

Richard D. Plecker

RICHARD PLECKER
ENVIRONMENTAL UTILITIES DIRECTOR



ENVIRONMENTAL UTILITIES
DEPARTMENT

**RESIDENTIAL 1"
SERVICE LINE**

SCALE: NONE
REVISED: JANUARY 2022
DRAWN BY: J. VAROZZA
APPROVED BY: RICHARD PLECKER

W-5

- 1) CONCRETE VALVE BOX (G-5 PER DETAIL W-16)
- 2) 6" CONTINUOUS BLUE SCHEDULE 40 PVC RISER (NOTCHED OVER PIPE AT BASE)
- 3) CURB STOP
- 4) METER RESETTER WITH IDLER
- 5) N-16 UTILITY BOX OR APPROVED EQUAL for 3/4" N-30 UTILITY BOX OR APPROVED EQUAL for 1"
- 6) METER (PURCHASED THROUGH CITY)
- 7) R.P TYPE BACKFLOW DEVICE
- 8) PRESSURE REGULATOR IS ALL BRASS (NOT REQUIRED FOR IRRIGATION SERVICE)

- 9) BALL VALVES
- 10) BRASS STRAINER WITH BRASS PLUG
- 11) SCH. 40 P.V.C. THROUGH PIPE EYE
- 12) INSTALL (2) UNIONS NOT CONNECTED TO PRESSURE REGULATOR
- 13) METER SPUDS
- 14) BRASS PLUG
- 15) CONCRETE COLLAR (SEE DETAIL W-16)

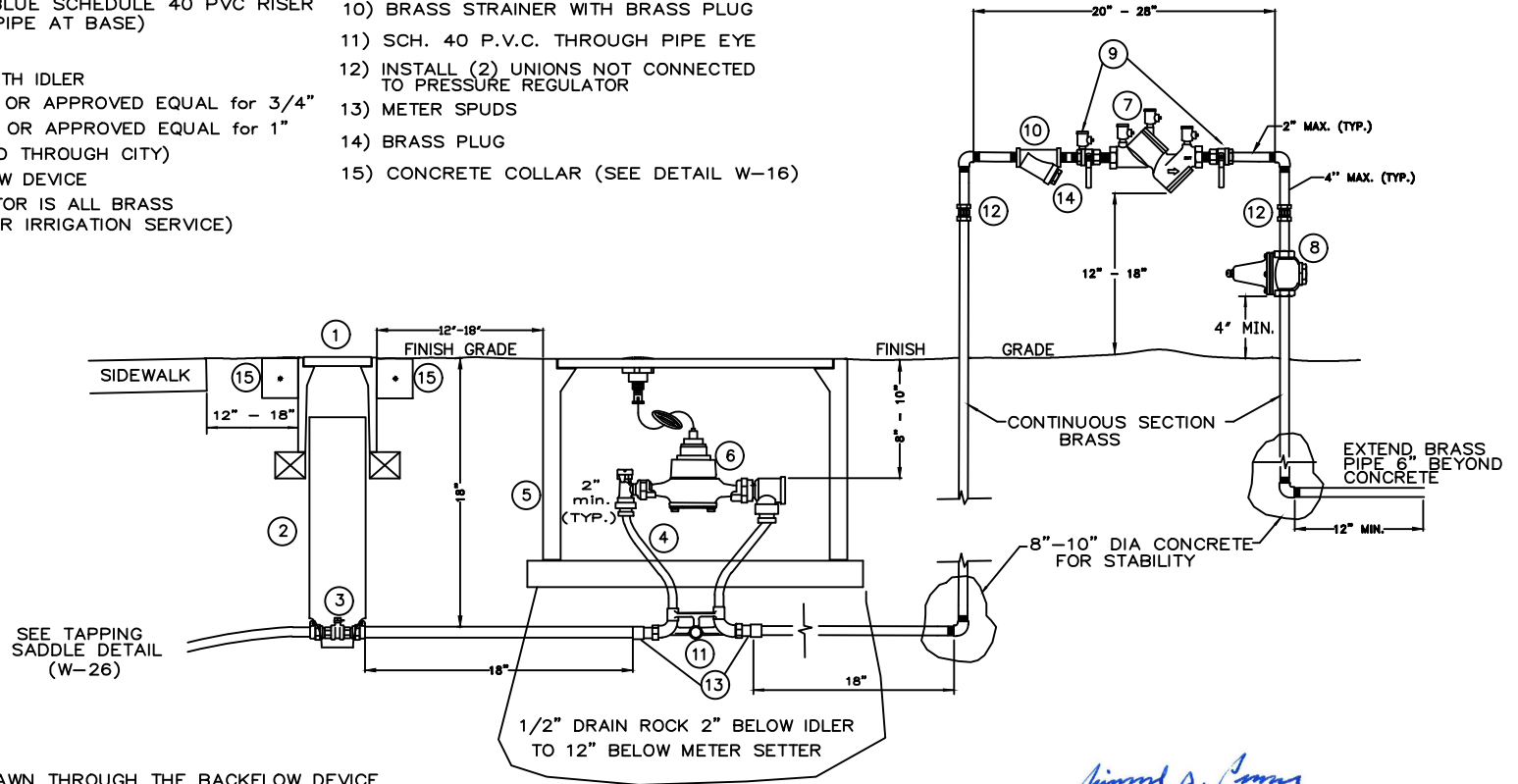

NOTES:

NO WATER SHALL BE DRAWN THROUGH THE BACKFLOW DEVICE UNTIL IT HAS BEEN TESTED BY THE ENVIRONMENTAL UTILITIES DEPT.

ALL FITTINGS AND PIPING SHALL BE BRASS BEGINNING AT CURB STOP

IF USED FOR IRRIGATION DO NOT INCLUDE PRESSURE REGULATOR.

INSTALL (3" X 5") CONCRETE BRICK UNDER PERIMETER OF UTILITY BOXES.

WATER METERS SHALL BE PURCHASED THROUGH THE CITY. PURCHASE INCLUDES INSTALLATION.

THE BACKFLOW DEVICE SHALL BE INSULATED WITH A CITY APPROVED FREEZE PROTECTION BAG.

BURIED PIPE AND FITTINGS SHALL BE WRAPPED WITH 8 MIL POLYETHYLENE OR APPROVED EQUAL.

Richard D. Plecker

RICHARD PLECKER
ENVIRONMENTAL UTILITIES DIRECTOR



ENVIRONMENTAL UTILITIES
DEPARTMENT

**COMMERCIAL 1"
SERVICE LINE**

SCALE: NONE
REVISED: JANUARY 2020
DRAWN BY: R. VAN NESS
APPROVED BY: RICHARD PLECKER

W-6

NOTES:

NO WATER SHALL BE DRAWN THROUGH THE BACKFLOW DEVICE UNTIL IT HAS BEEN TESTED BY THE ENVIRONMENTAL UTILITIES DEPT.

WATER METERS SHALL BE PURCHASED THROUGH THE CITY. PURCHASE INCLUDES INSTALLATION.

THE BACKFLOW DEVICE SHALL BE INSULATED WITH A CITY APPROVED FREEZE PROTECTION BAG.

THERE SHALL BE NO FLOW ALTERING DEVICES 5X THE PIPE DIAMETER UPSTREAM AND DOWNSTREAM OF THE METER.

CURBSTOP SHALL BE BETWEEN 12" & 18" OF EASEMENT.

FITTINGS AND PIPING SHALL BE BRASS.

BURIED PIPE AND FITTINGS SHALL BE WRAPPED WITH 8 MIL POLYETHYLENE OR APPROVED EQUAL.

PAINT BACKFLOW FOREST GREEN RAL 6004

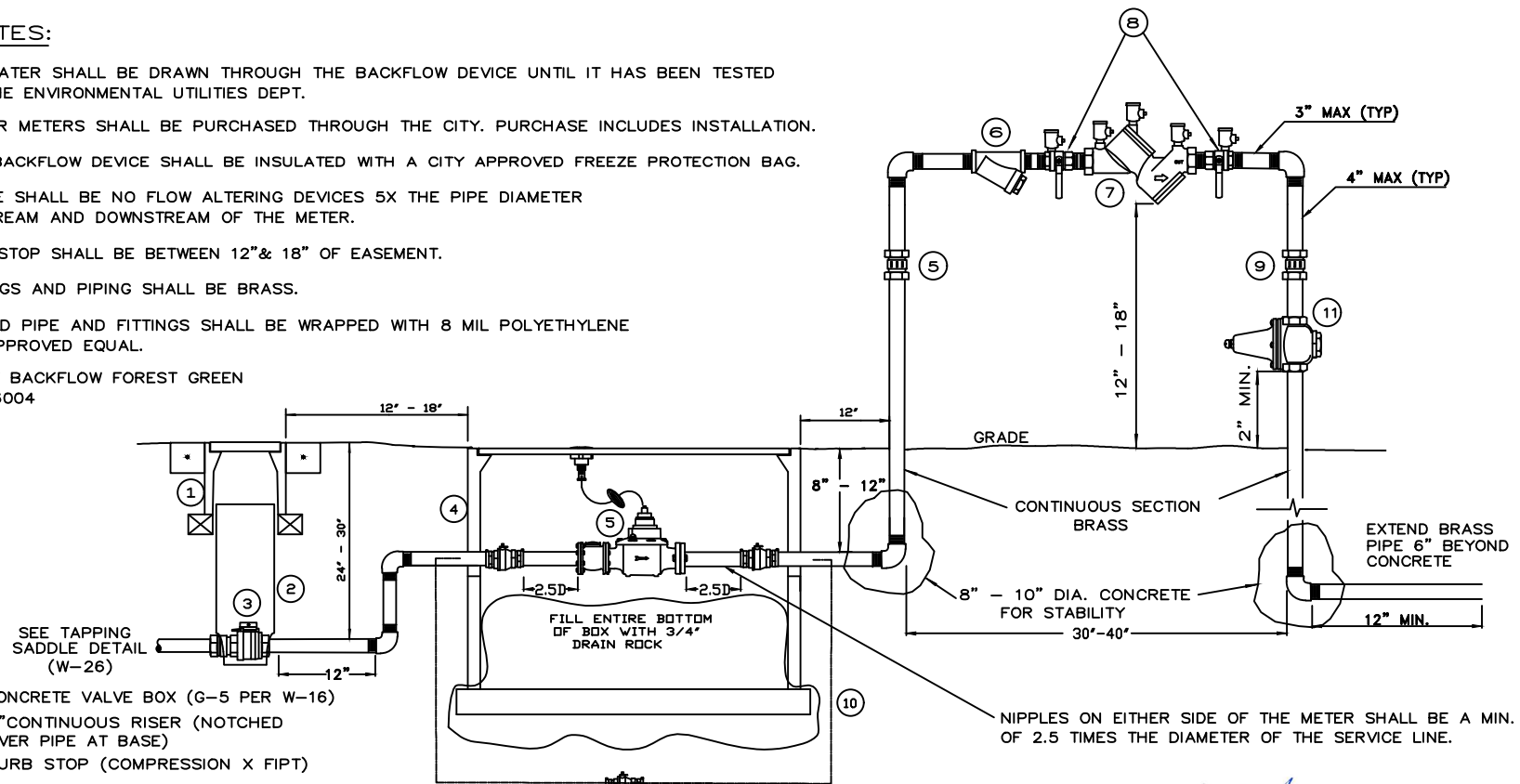

- 1) CONCRETE VALVE BOX (G-5 PER W-16)
- 2) 6" CONTINUOUS RISER (NOTCHED OVER PIPE AT BASE)
- 3) CURB STOP (COMPRESSION X FIPT)
- 4) B-40 UTILITY BOX W/ EXTENSION (MORTAR JOINTS INSIDE & OUT)
- 5) TURBO METER WITH STRAINER FOR IRRIGATION. COMPOUND METER FOR COMMERCIAL (PURCHASED THROUGH CITY). INSTALL IDLER SPOOL DURING INSTALLATION OF METER BOX.
- 6) "Y" STRAINER WITH BRASS PLUG
- 7) R.P. TYPE BACKFLOW DEVICE
- 8) BALL VALVES
- 9) INSTALL (2) UNIONS
- 10) CONCRETE BRICK (4"x4"x15 1/2") UNDER ENTIRE PERIMETER OF UTILITY BOX
- 11) BRASS PRESSURE REGULATOR NOT REQUIRED FOR IRRIGATION SERVICE
- 12) 3/4" LOCKING CURB STOP IN G-5 BOX NOT REQUIRED FOR IRRIGATION SERVICE
- 13) 3/4" BY PASS MATERIAL TO BE SOFT COPPER TYPE K AND FITTINGS TO BE BRASS COMPRESSION TYPE. NOT REQUIRED FOR IRRIGATION SERVICE
- 14) OR, FOR APPLICABLE LID TYPE, REFER TO METER APPLICATION TABLE AT THE END OF MATERIALS SECTION.

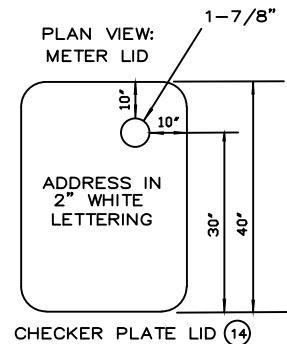
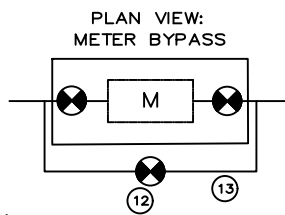

Richard D. Samuelson
 RICHARD PLECKER
 ENVIRONMENTAL UTILITIES DIRECTOR

	ENVIRONMENTAL UTILITIES DEPARTMENT
COMMERCIAL/IRRIGATION 1 1/2" & 2" SERVICE LINE	
SCALE: NONE REVISED: JANUARY 2021 DRAWN BY: D.SAMUELSON APPROVED BY: RICHARD PLECKER	
W-7	

MATERIALS:

- 1) R.P. TYPE BACKFLOW DEVICE (CITY APPROVED)
- 2) 4" THICK REINFORCED CONCRETE SLAB WITH #4 REBAR 12" ON CENTER
- 3) THRUST BLOCKS (TYP.)
- 4) SUPPORT STANDS BOLTED INTO CONCRETE
- 5) 1/4" NON-CASE HARDENED CHAIN WITH BREAKAWAY LOCK(TWO BOLTS MINIMUM)

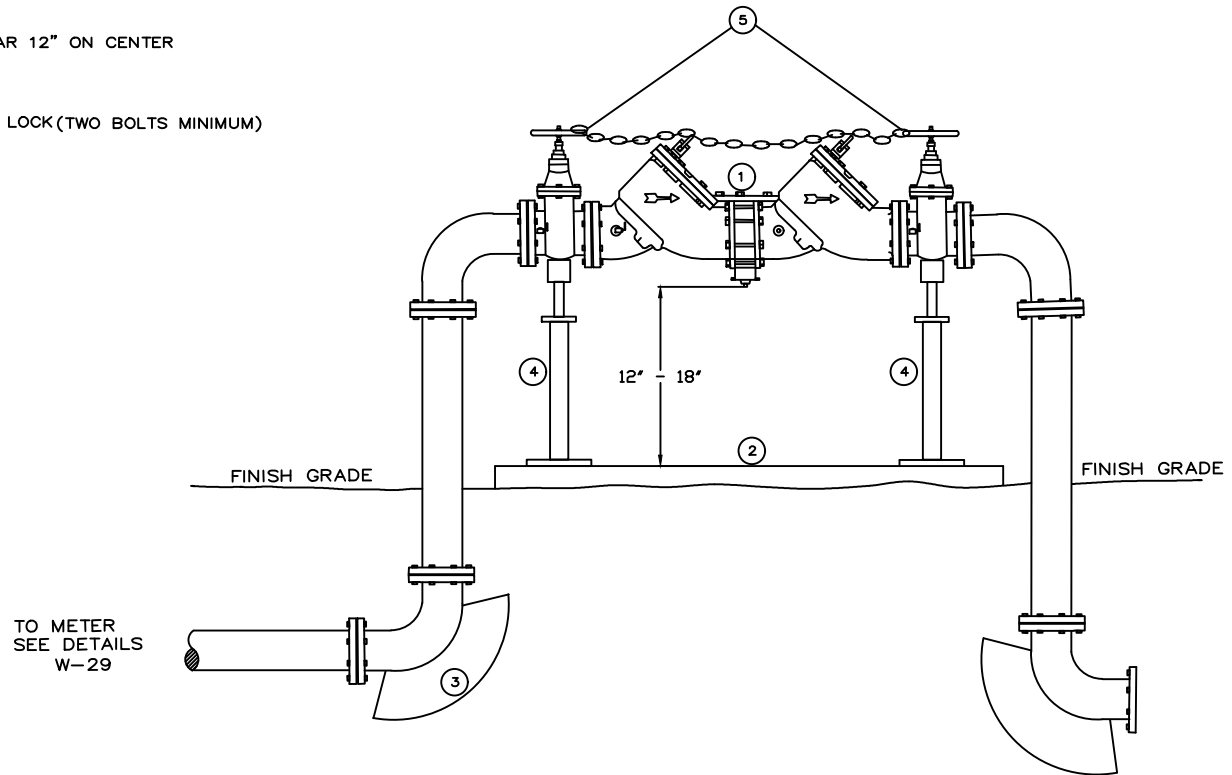

NOTES:

NO WATER IS TO BE DRAWN THROUGH THE BACKFLOW DEVICE UNTIL IT HAS BEEN TESTED BY THE ENVIRONMENTAL UTILITIES DEPT.

PIPE SHALL BE DUCTILE IRON.

PIPE AND FITTINGS SHALL BE WRAPPED WITH 8 MIL. POLYETHYLENE

USE CITY APPROVED RESTRAINED JOINTS OR FLANGED SPOOLS

THE BACKFLOW DEVICE SHALL BE INSULATED WITH A CITY APPROVED FREEZE PROTECTION BAG.

Richard D. Plecker

RICHARD PLECKER
ENVIRONMENTAL UTILITIES DIRECTOR

CITY OF
ROSEVILLE
CALIFORNIA

ENVIRONMENTAL UTILITIES
DEPARTMENT

**COMMERCIAL 3" & LARGER
SERVICE**

SCALE: NONE
REVISED: JANUARY 2023
DRAWN BY: J THOMPSON
APPROVED BY: RICHARD PLECKER

W-8

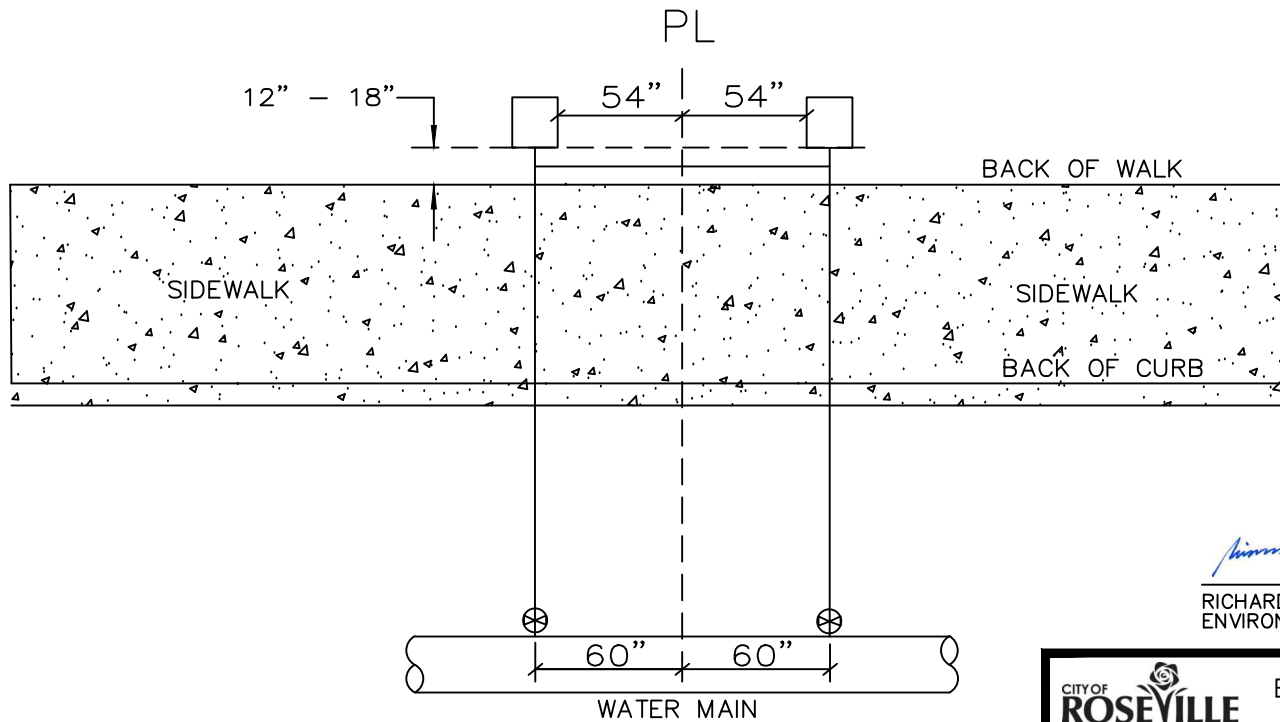

Richard D. Plecker

RICHARD PLECKER
ENVIRONMENTAL UTILITIES DIRECTOR

CITY OF
ROSEVILLE
CALIFORNIA

ENVIRONMENTAL UTILITIES
DEPARTMENT

RESIDENTIAL WATER SERVICE

SCALE: NONE
REVISED: JANUARY 2016
DRAWN BY: R. VAN NESS
APPROVED BY: RICHARD PLECKER

W-9

NOTE: REFER TO DETAIL W-18 FOR "WATER SERVICE TRENCH AND BACKFILL"

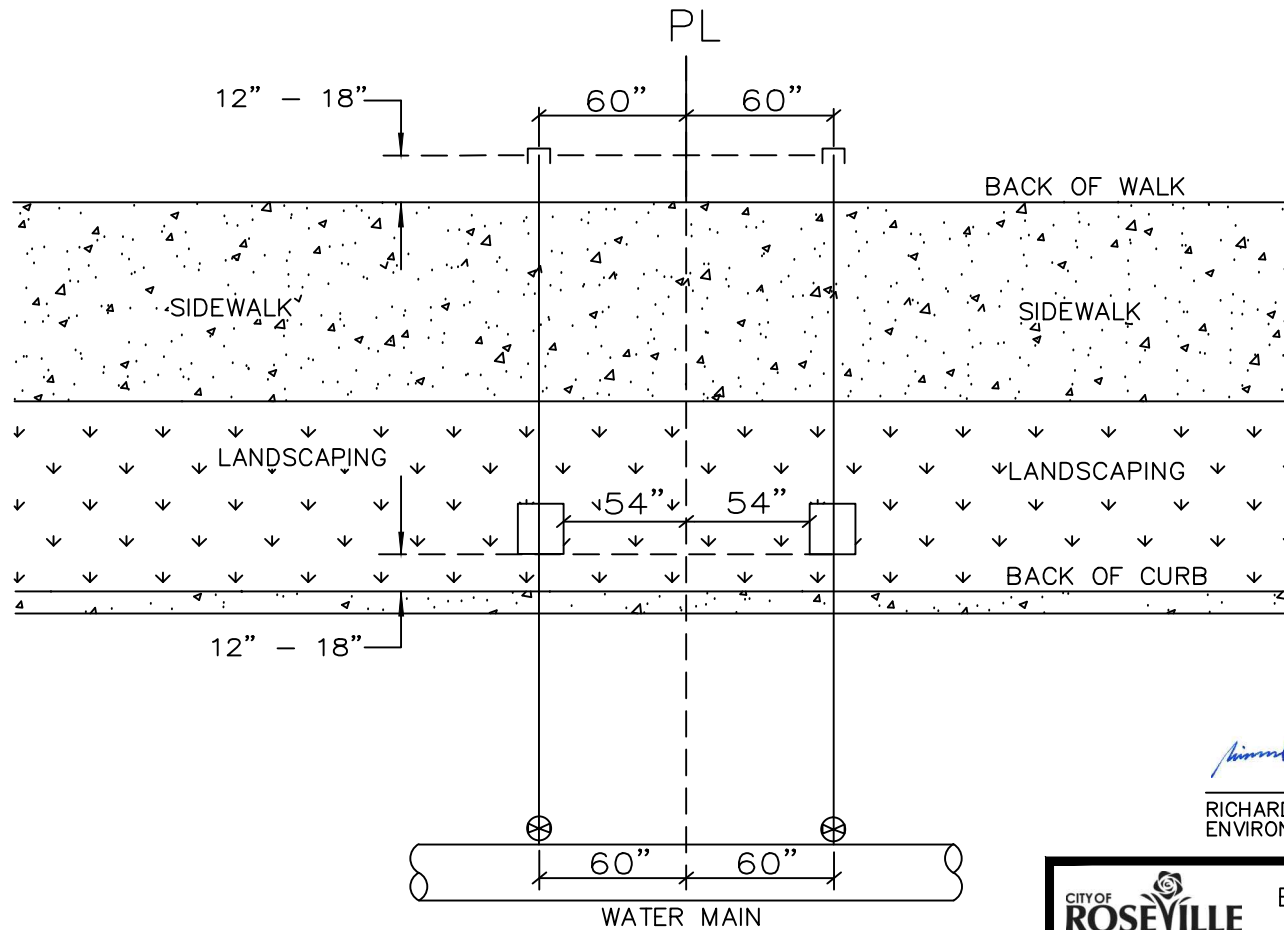

Richard D. Plecker

RICHARD PLECKER
ENVIRONMENTAL UTILITIES DIRECTOR



ENVIRONMENTAL UTILITIES
DEPARTMENT

**RESIDENTIAL WATER SERVICE FOR
SEPARATED SIDEWALKS**

SCALE: NONE
REVISED: JANUARY 2016
DRAWN BY: R. VAN NESS
APPROVED BY: RICHARD PLECKER

W-10

NOTE: REFER TO DETAIL W-18 FOR "WATER SERVICE TRENCH AND BACKFILL"

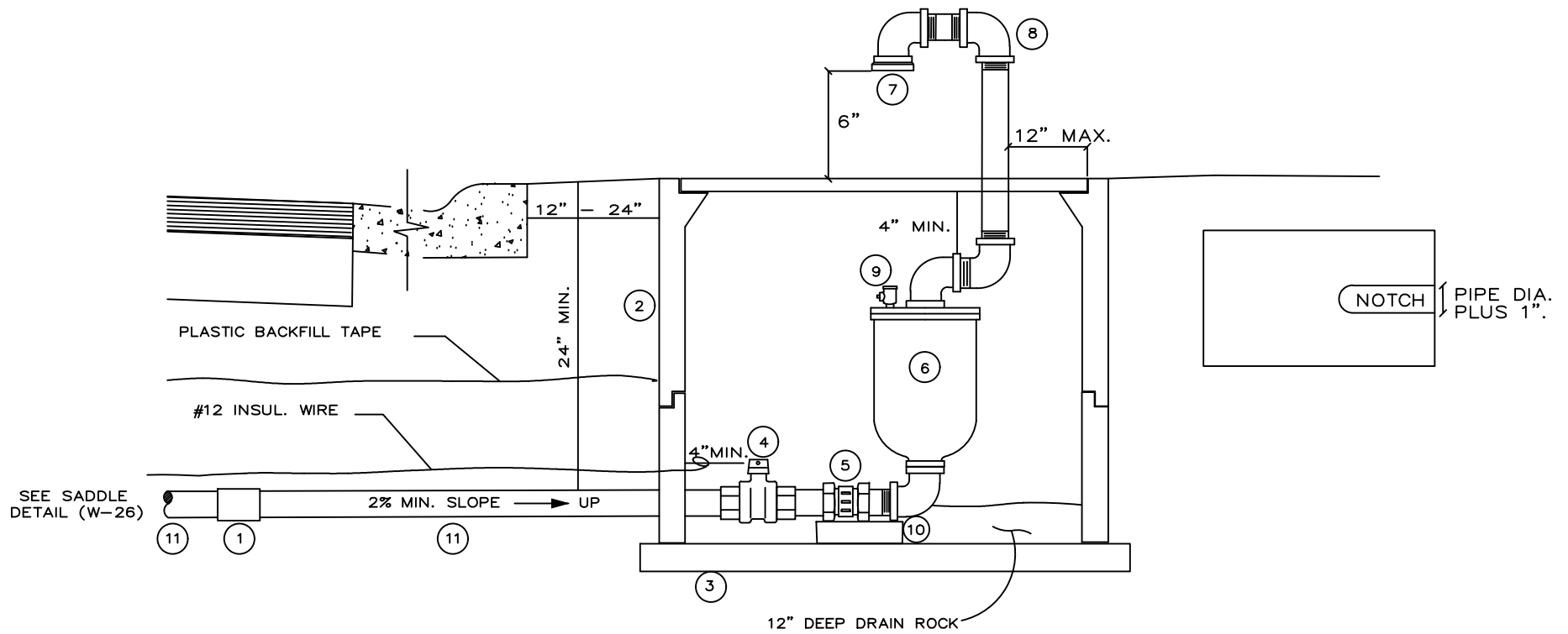

- 1) BRASS THREADED COUPLING (IF REQUIRED)
- 2) B-40 UTILITY BOX W/TRAFFIC COVER MARKED, "RSVL ARV" IF EXTENSION IS REQ. MOTAR EXTENSION JOINT INSIDE & OUT.
- 3) 3" x 5" CONCRETE BRICK UNDER ENTIRE PERIMETER OF UTILITY BOX.
- 4) CURB STOP
- 5) BRASS UNION
- 6) COMBINATION AIR / VACUUM VALVE
- 7) BRASS CAP WITH 9 DRILLED 1/16" HOLES OR APPROVED EQUAL.
- 8) USE GALVANIZED PIPE AND FITTINGS ABOVE GROUND
- 9) 1/4" TEST COCK
- 10) CONCRETE BLOCK FOR SUPPORT
- 11) THREADED BRASS PIPE

NOTE:

BURIED PIPE AND FITTINGS SHALL BE WRAPPED WITH 8 MIL POLYETHYLENE OR APPROVED EQUAL.

Richard D. Plecker

RICHARD PLECKER
ENVIRONMENTAL UTILITIES DIRECTOR

CITY OF
ROSEVILLE
CALIFORNIA

ENVIRONMENTAL UTILITIES
DEPARTMENT

**1" AND 2" AIR RELEASE
VALVE ASSEMBLY**

SCALE: NONE
REVISED: JANUARY 2017
DRAWN BY: R. VAN NESS
APPROVED BY: RICHARD PLECKER

W-12

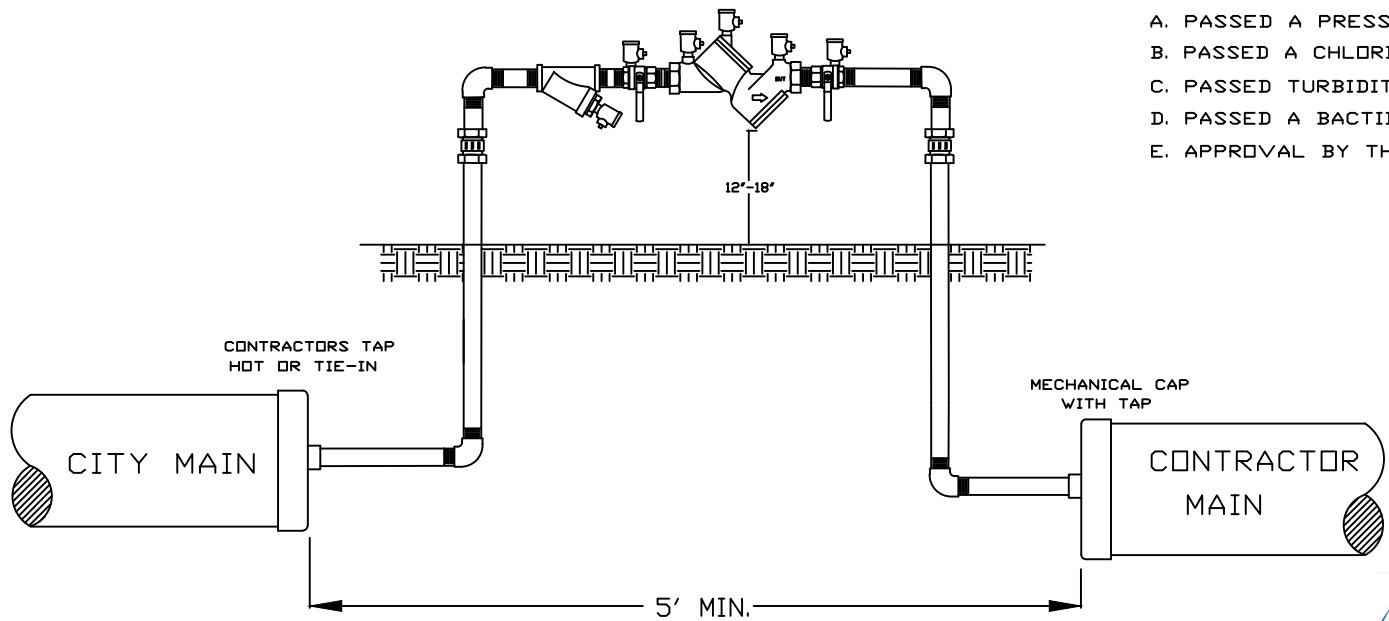

PRIOR TO CONNECTION TO THE CITY MAIN, THE FOLLOWING CONDITIONS SHALL BE MET:

- A. PASSED A PRESSURE TEST
- B. PASSED A CHLORINE TEST
- C. PASSED TURBIDITY TEST
- D. PASSED A BACTII TEST
- E. APPROVAL BY THE EUD INSPECTOR

NOTES:

WATER SHALL ONLY BE DRAWN INTO THE CONTRACTORS MAIN THROUGH A CITY APPROVED RP TYPE BACKFLOW DEVICE WHICH HAS BEEN TESTED AND TAGGED BY THE ENVIRONMENTAL UTILITIES DEPARTMENT.

FINAL SYSTEM COMPONENTS NECESSARY FOR TIE-IN SHALL BE PRE-CHLORINATED AND PRE-FLUSHED IN THE PRESENCE OF AN ENVIRONMENTAL UTILITIES DEPARTMENT INSPECTOR.

UPON COMPLETION OF THE CONDITIONS NOTED ABOVE AND WITH THE APPROVAL OF THE EUD INSPECTOR, CONNECTION TO THE CITY SYSTEM MAY BE MADE. THE EUD INSPECTOR SHALL BE NOTIFIED 48 HOURS PRIOR TO THE START OF WORK.

CONTRACTOR IS TO SIZE JUMPER ADEQUATELY FOR FLUSHING PURPOSES.

Richard D. Plecker

RICHARD PLECKER
ENVIRONMENTAL UTILITIES DIRECTOR



CITY OF ROSEVILLE
ENVIRONMENTAL UTILITIES DEPT.

CONSTRUCTION WATER DETAIL

SCALE: NONE
REVISED: JANUARY 2017
DRAWN BY: R. VAN NESS
APPROVED BY: RICHARD PLECKER

W-14

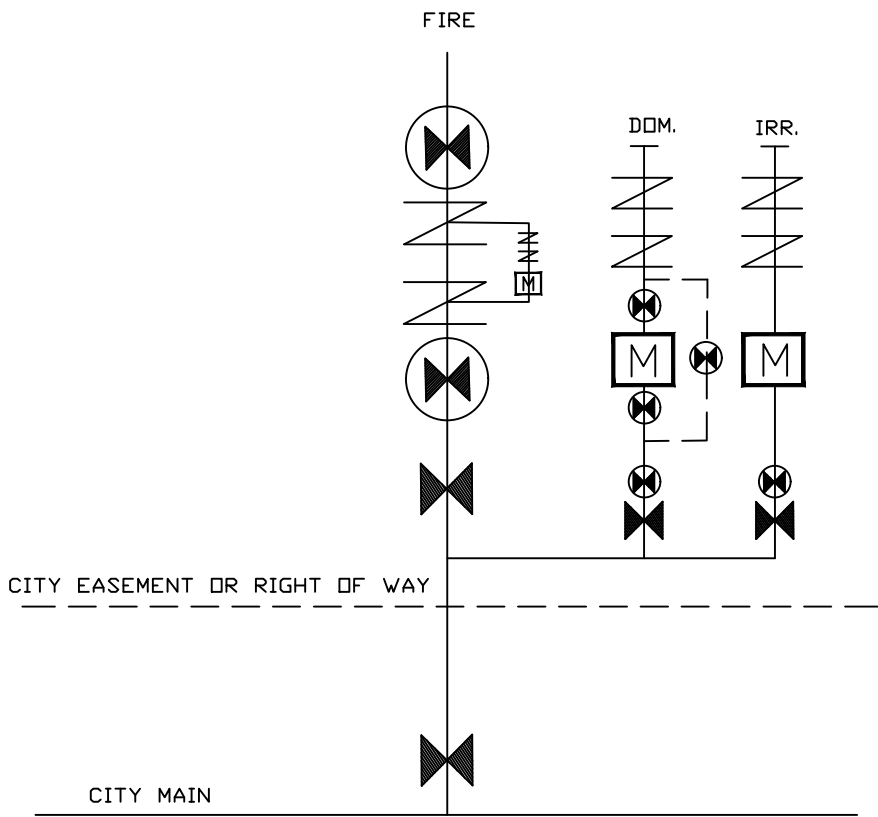

NOTES:

- 1) RESTRAINT ENTIRE MANIFOLD WITH APPROVED RESTRAINT SYSTEMS.
- 2) TAPS SHALL BE MADE SUCH THAT NO DEAD END LINES RESULT.
- 3) ALL LINES 3" AND LARGER SHALL BE DIP.
- 4) AFTER THE MANIFOLD, UNDERGROUND AND ABOVE, HAS BEEN ACCEPTED, METERS SHALL BE PURCHASED THROUGH THE CITY AND INSTALLED BY CITY CREWS. WATER MAY NOT DRAWN PRIOR TO TESTING AND TAGGING THE BACKFLOW DEVICE BY THE EUD
- 5) PROVIDE A PAD WITHIN THE LIMITS OF THE BACKFLOW MANIFOLD WITH POSITIVE DRAINAGE AND A 2% MAX. SLOPE.
- 6) IN A BACKFLOW MANIFOLD CONFIGURATION THAT INCLUDES DOMESTIC AND IRRIGATION SERVICES, THE IRRIGATION SERVICE TAP SHALL BE DOWNSTREAM OF THE DOMESTIC SERVICE TAP.
- 7) PROVIDE A MINIMUM 3 FOOT SEPARATION BETWEEN BACKFLOWS IN PARALLEL.
- 8) PROVIDE A 3' MINIMUM CLEARANCE FROM TOE OR TOP OF ANY SLOPE. NO SLOPES GREATER THAN 2:1 ADJACENT TO BACKFLOW MANIFOLD. IF THE ABOVE CRITERIA IS NOT MET, A RETAINING WALL IS REQUIRED. THE RETAINING WALL SHALL BE CONSTRUCTED OF CONCRETE OR MASONRY ONLY.
- 9) PROVIDE CURB STOPS AS REQUIRED PER THESE STANDARDS.
- 10) METER LID SHALL BE STENCILLED WITH THE NUMBER ADDRESS IT SERVES. USE WHITE ENAMEL PAINT AND 2" TALL STENCILING.
- 11) A METER BYPASS WITH A LOCKING CURB STOP OR LOCKING VALVE SHALL BE REQUIRED FOR ALL DOMESTIC SERVICES 3" AND LARGER OR WHERE REQUIRED.
- 12) MANIFOLD PIPING SHALL BE A MAXIMUM DEPTH OF 6 FEET.
- 13) MANIFOLD PIPING CONNECTING THE DOMESTIC AND IRRIGATION SERVICES SHALL BE 4" MINIMUM DIP BEYOND THE TEE CONNECTION WITH THE FIRE SERVICE.

Richard D. Plecker

RICHARD PLECKER
ENVIRONMENTAL UTILITIES DIRECTOR



ENVIRONMENTAL UTILITIES
DEPARTMENT

BACKFLOW MANIFOLD SCHEMATIC

SCALE: NONE
REVISED: JANUARY 2022
DRAWN BY: R. VAN NESS
APPROVED BY: RICHARD PLECKER

W-15

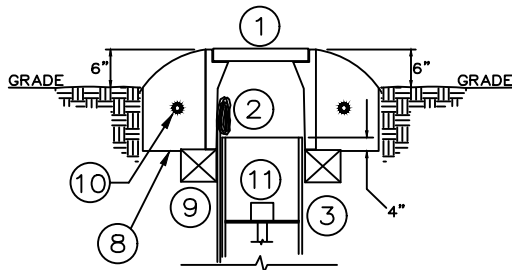

UNDEVELOPED AREA

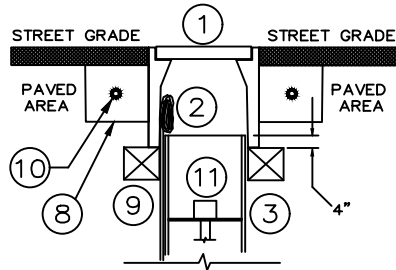

PAVED AREA

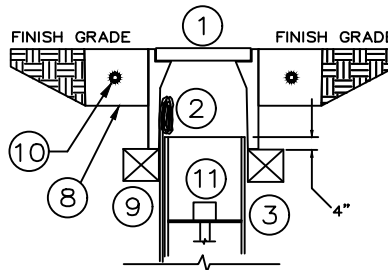

LANDSCAPED AREA

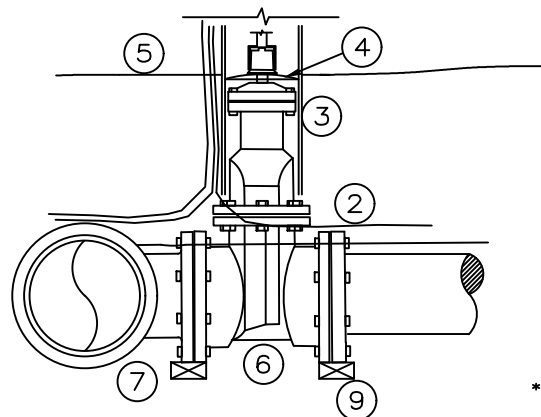

GATE VALVE

MATERIALS

- 1) CONCRETE VALVE BOX
- 2) #12 INSULATED TRACING WIRE OUTSIDE RISER
- 3) 8" RISER STOCK
- 4) RISER ALIGNER
- 5) PLASTIC BACKFILL TAPE
- 6) GATE VALVE
- 7) DUCTILE IRON TEE
- 8) CONCRETE COLLAR (SEE NOTES) *
- 9) CONCRETE BRICK (SEE NOTES)
- 10) #4 REBAR AROUND CIRCUM. (TYP.)
- 11) VALVE EXTENSION PER SECTION 81-12.B

* CONCRETE COLLAR SHALL BE PLACED FLUSH TO FINISH GRADE IN ALL COLLECTORS AND ARTERIALS, OPTIONAL IN ALL OTHER ROADWAYS. FINISH SURFACE SHALL BE MEDIUM BROOM FINISH WITH PATTERN PERPENDICULAR TO VEHICLE TRAVEL DIRECTION. SET COLLAR 1/8" BELOW ADJACENT FINISHED PAVEMENTS.

NOTES:

TRACING WIRE THROUGH VALVE BOXES SHALL BE PLACED OUTSIDE OF RISER BUT INSIDE OF BOX.

TRACING WIRE SHALL BE SPLICED INSIDE THE VALVE BOX PER (W-17) AND SHALL LOOP WITHIN THE VALVE BOX WITH 18" OF SLACK WIRE

ALL GATE VALVES SHALL BE CENTERED IN A ONE PIECE RISER STOCK WITH THE USE OF A RISER ALIGNER

OPERATOR NUTS DEEPER THAN 40 INCHES FROM FINISH GRADE SHALL REQUIRE A VALVE NUT EXTENSION 2 FEET MINIMUM IN LENGTH.

VALVE BOXES LOCATED IN A PAVED AREA SHALL BE PLACED IN A 6" X 6" CONCRETE COLLAR A MINIMUM OF 3" BELOW PAVEMENT

VALVE BOXES LOCATED IN A LANDSCAPED AREA SHALL BE PLACED IN A 6" X 6" CONCRETE COLLAR AT FINISHED GRADE.

VALVE BOXES LOCATED IN AN UNDEVELOPED AREA SHALL BE PLACED IN A 12" DEEP BY 6" WIDE CONCRETE COLLAR 6 INCHES ABOVE GRADE.

INSTALL (3" X 5" CONCRETE BRICK) UNDER ENTIRE PERIMETER OF BOX.

VALVES AND FITTINGS SHALL BE WRAPPED AND SEALED IN 8 MIL POLYETHYLENE

VALVE RISOR STOCK SHALL BE A MINIMUM OF 4" INSIDE VALVE BOX AND MINIMUM 2" BELOW METAL RING.

Richard D. Plecker

RICHARD PLECKER
ENVIRONMENTAL UTILITIES DIRECTOR



ENVIRONMENTAL UTILITIES
DEPARTMENT

GATE VALVE & BOX

SCALE: NONE
REVISED: JANUARY 2020
DRAWN BY: R. VAN NESS
APPROVED BY: RICHARD PLECKER

W-16

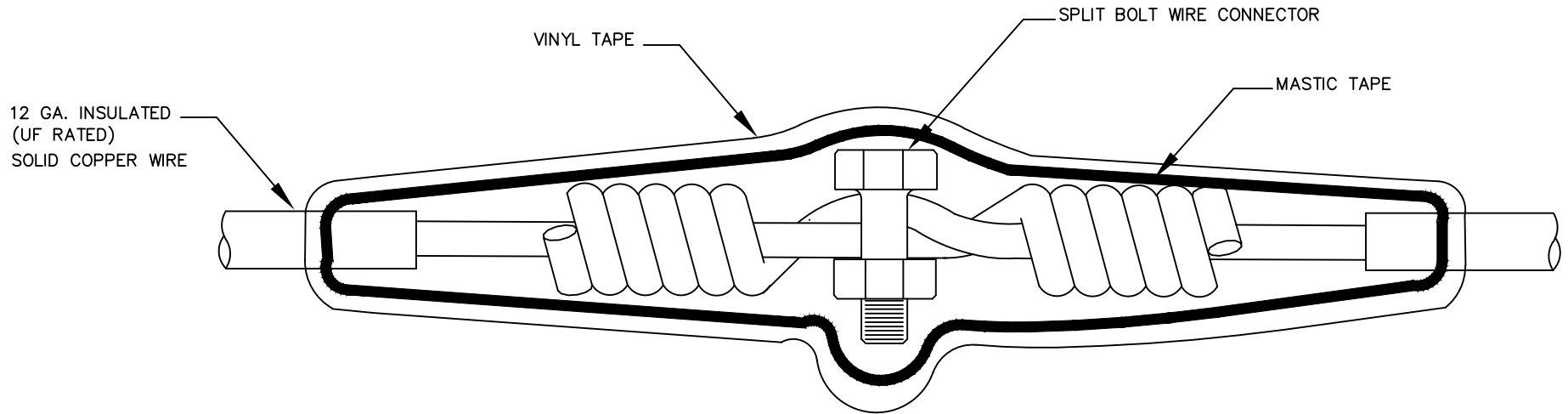

NOTES:

1. TWIST THE WIRE A MINIMUM OF (5) TIMES ON EACH END.
2. INSTALL SPLIT BOLT CONNECTOR.
3. SOLDER WIRE
4. COVER THE ENTIRE SPLICE WITH MASTIC TAPE WRAP
5. WRAP MASTIC WITH VINYL TAPE.
6. WIRE SPLICES SHALL BE LOCATED WITHIN A VALVE BOX PER DETAIL W-16.

Richard D. Plecker

RICHARD PLECKER
ENVIRONMENTAL UTILITIES DIRECTOR

CITY OF
ROSEVILLE
CALIFORNIA

ENVIRONMENTAL UTILITIES
DEPARTMENT

TRACING WIRE SPLICE

SCALE: NONE
REVISED: JANUARY 2016
DRAWN BY: R. VAN NESS
APPROVED BY: RICHARD PLECKER

W-17

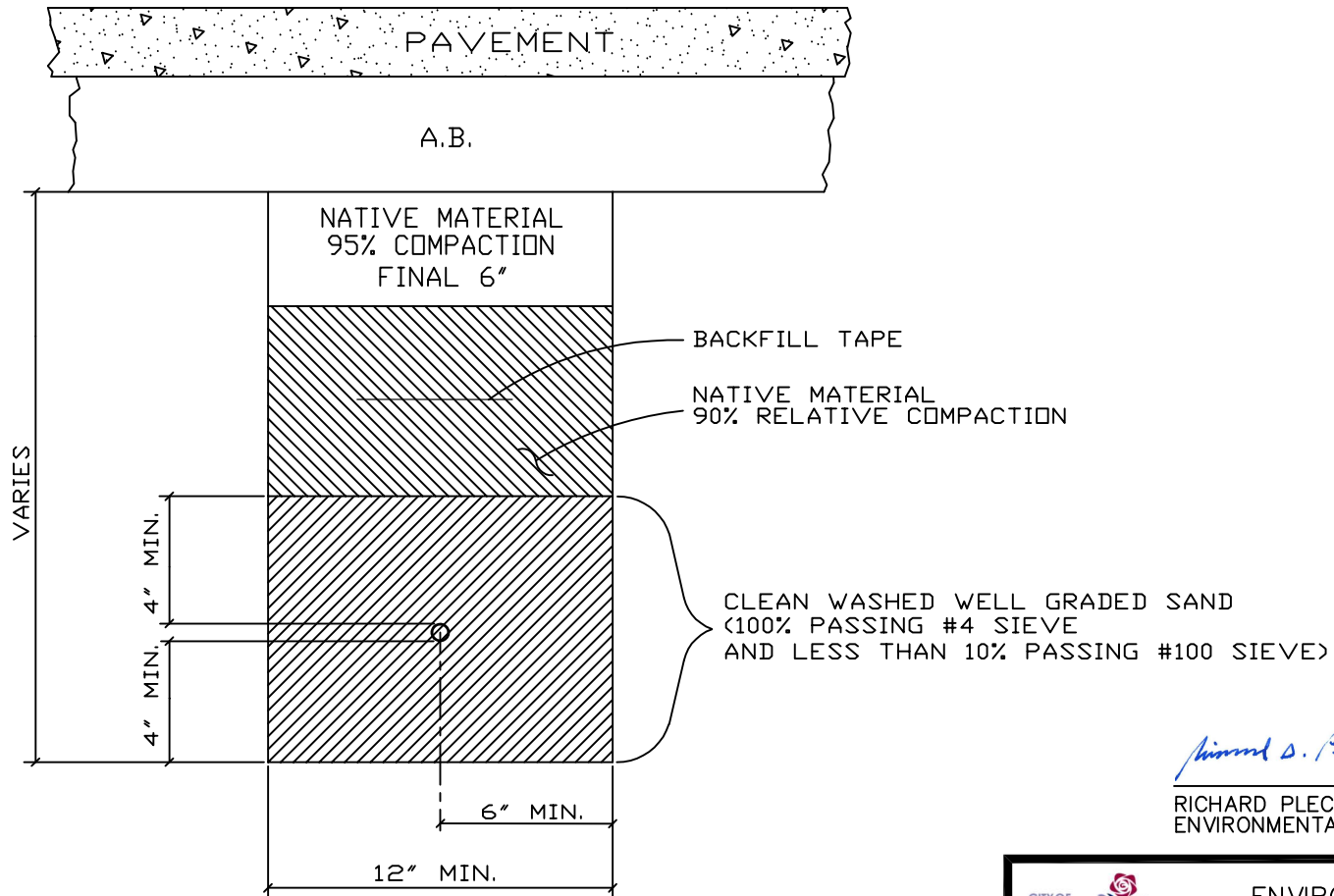

Richard D. Plecker

RICHARD PLECKER
ENVIRONMENTAL UTILITIES DIRECTOR



ENVIRONMENTAL UTILITIES
DEPARTMENT

TRENCH AND BACKFILL FOR ALL
WATER LINES 2" AND SMALLER

SCALE: NONE
REVISED: JANUARY 2016
DRAWN BY: R. VAN NESS
APPROVED BY: RICHARD PLECKER

W-18

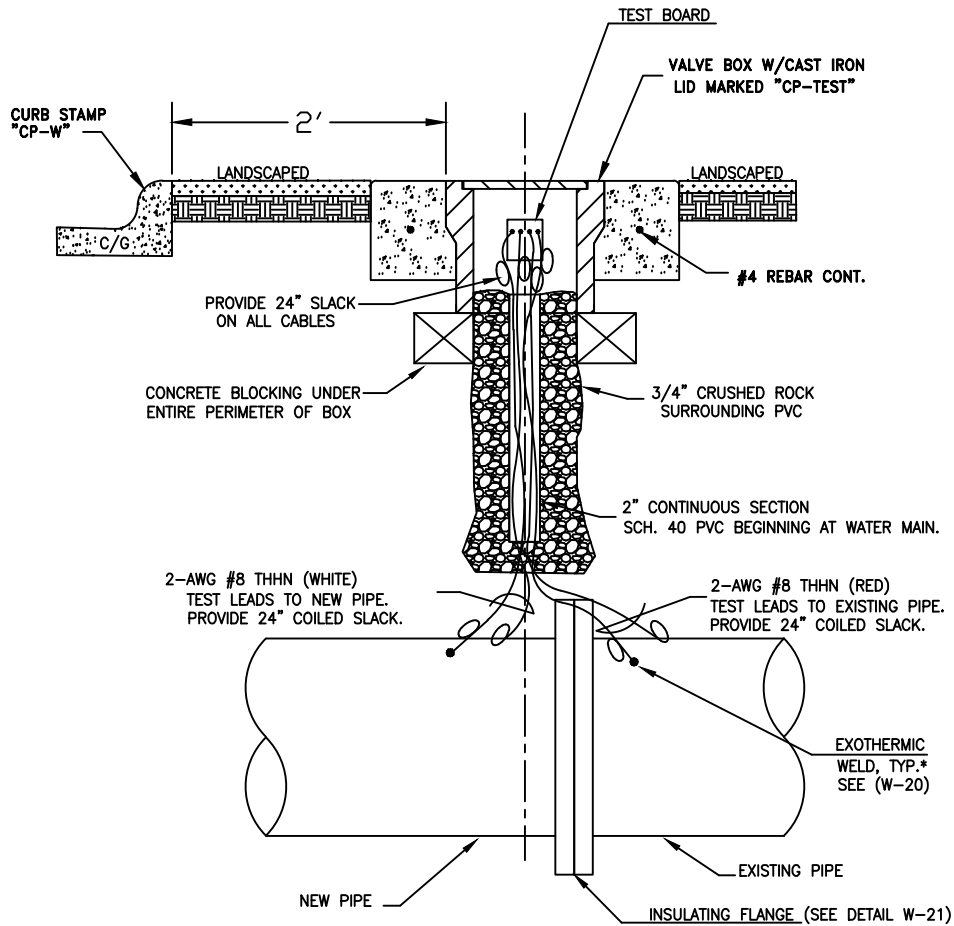

TEST STATION (TYPICAL)

*FOR VALVES WELD ON FLANGE

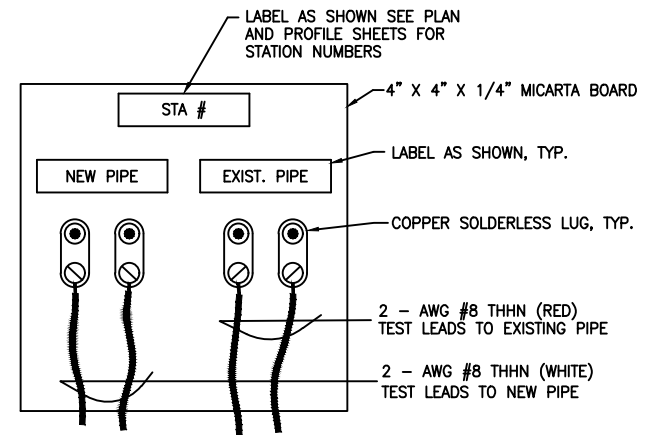

TEST STATION BOARD (TYPICAL)

Richard D. Plecker

RICHARD PLECKER
ENVIRONMENTAL UTILITIES DIRECTOR



ENVIRONMENTAL UTILITIES
DEPARTMENT

INSULATING FLANGE TEST STATION

SCALE: NONE
REVISED: JANUARY 2017
DRAWN BY: R. VAN NESS
APPROVED BY: RICHARD PLECKER

W-19

1) FILE TO BARE METAL & CLEAN OVER SURFACE

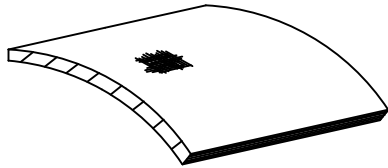

2) STRIP INSULATION FROM WIRE AND ATTACH SLEEVE

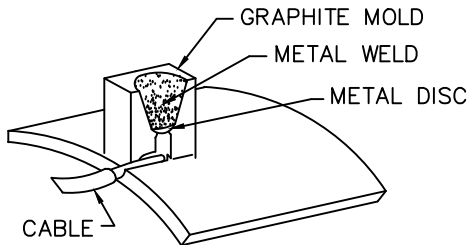
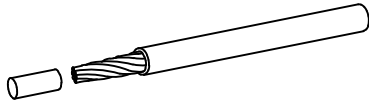

3) HOLD MOLD FIRMLY WITH OPENING AWAY FROM OPERATOR, IGNITE WITH FLINT GUN

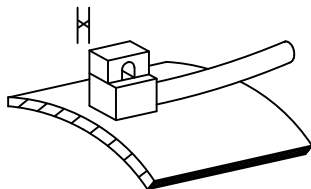

4) REMOVE SLAG FROM CONNECTION, COVER CONNECTION WITH COMPATIBLE COATING AND CAP OVER ALL EXPOSED METAL

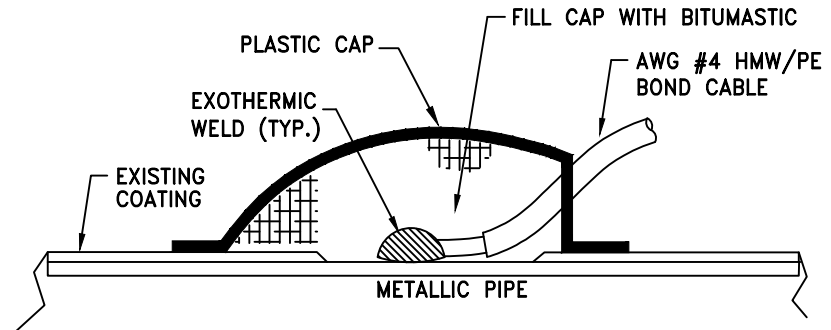
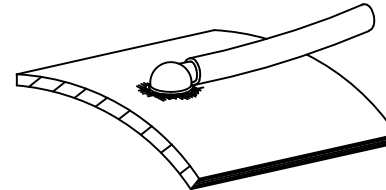

Richard D. Plecker

RICHARD PLECKER
ENVIRONMENTAL UTILITIES DIRECTOR

NOTE:
EACH JOINT SHALL HAVE TWO
SEPARATE WELD WIRES.



ENVIRONMENTAL UTILITIES
DEPARTMENT

EXOTHERMIC WELD

SCALE: NONE
REVISED: JANUARY 2016
DRAWN BY: R. VAN NESS
APPROVED BY: RICHARD PLECKER

W-20

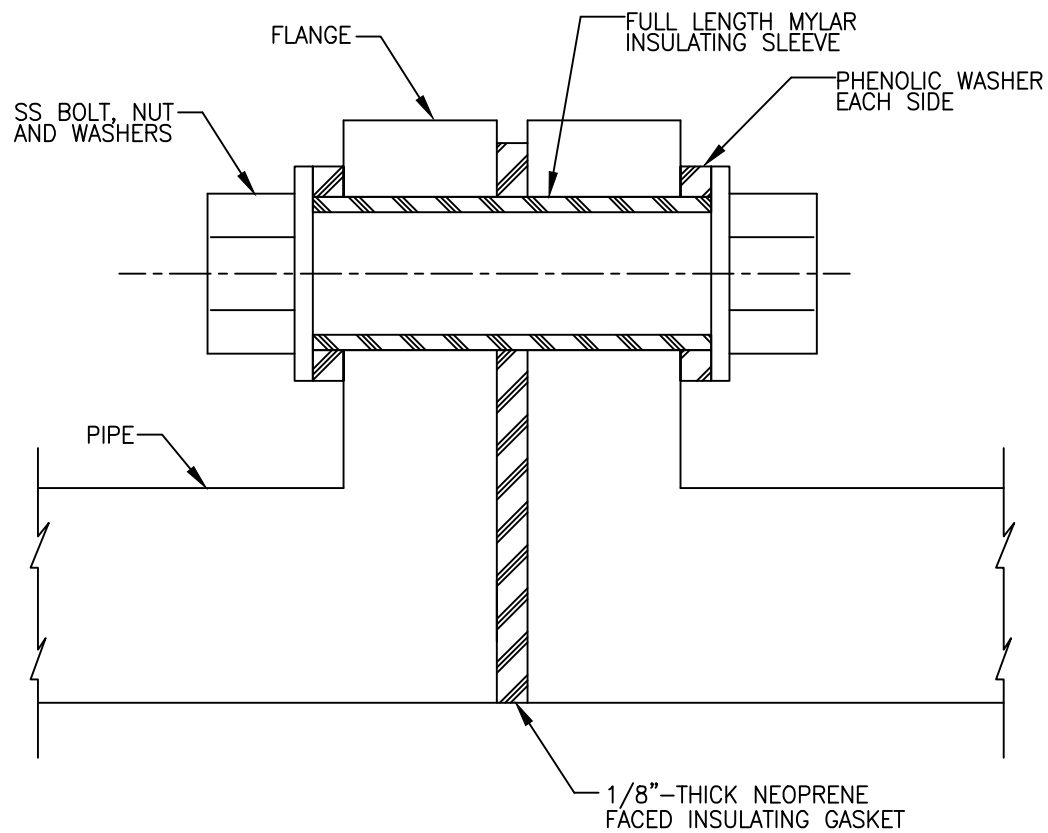

Richard D. Plecker

RICHARD PLECKER
ENVIRONMENTAL UTILITIES DIRECTOR

NOTES:

1. DIELECTRIC FLANGE KITS SHALL BE MANUFACTURED BY F.H. MALONEY CP., CALPICO OR APPROVED EQUAL
2. PROVIDE AN INSULATING FLANGE TEST STATION FOR THE INSULATED FLANGE.

CITY OF
ROSEVILLE
CALIFORNIA

ENVIRONMENTAL UTILITIES
DEPARTMENT

INSULATED FLANGE

SCALE: NONE
REVISED: JANUARY 2015
DRAWN BY: R. VAN NESS
APPROVED BY: RICHARD PLECKER

W-21

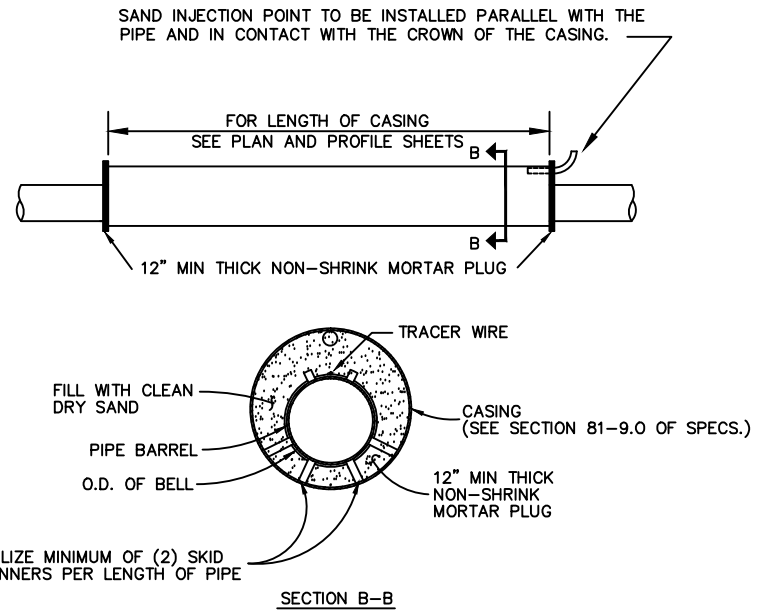
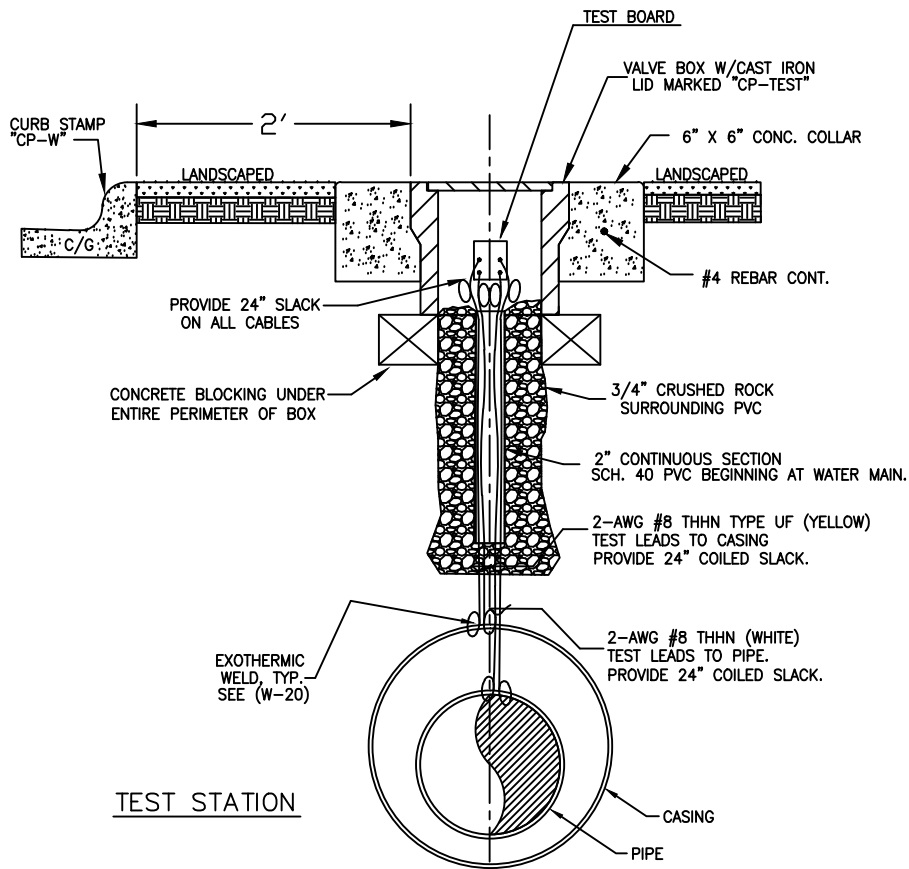

NOTES:

1. THE MINIMUM STRENGTH FOR STEEL CASING SHALL BE 35,000 PSI
2. 18 MIL COAL TAR EPOXY SHALL BE APPLIED ON THE INSIDE & OUTSIDE OF THE STEEL CASING.
3. RESTRAINED PIPE WITHIN CASINGS OR BRIDGES SHALL BE FULLY EXTENDED OR "STRETCHED OUT" TO REMOVE THE SLACK BETWEEN THE JOINTS THE ENTIRE LENGTH OF THE STRUCTURE.

CASING DETAIL

Richard D. Plecker

RICHARD PLECKER
ENVIRONMENTAL UTILITIES DIRECTOR

TEST BOARD

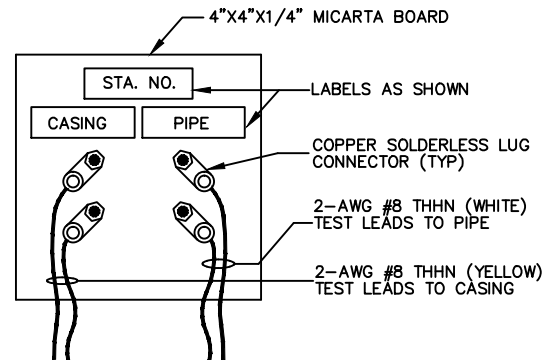

	<p>ENVIRONMENTAL UTILITIES DEPARTMENT</p>
	<p>CASING & TEST STATION</p>
<p>SCALE: NONE REVISED: JANUARY 2016 DRAWN BY: R. VAN NESS APPROVED BY: RICHARD PLECKER</p>	
<p>W-22</p>	

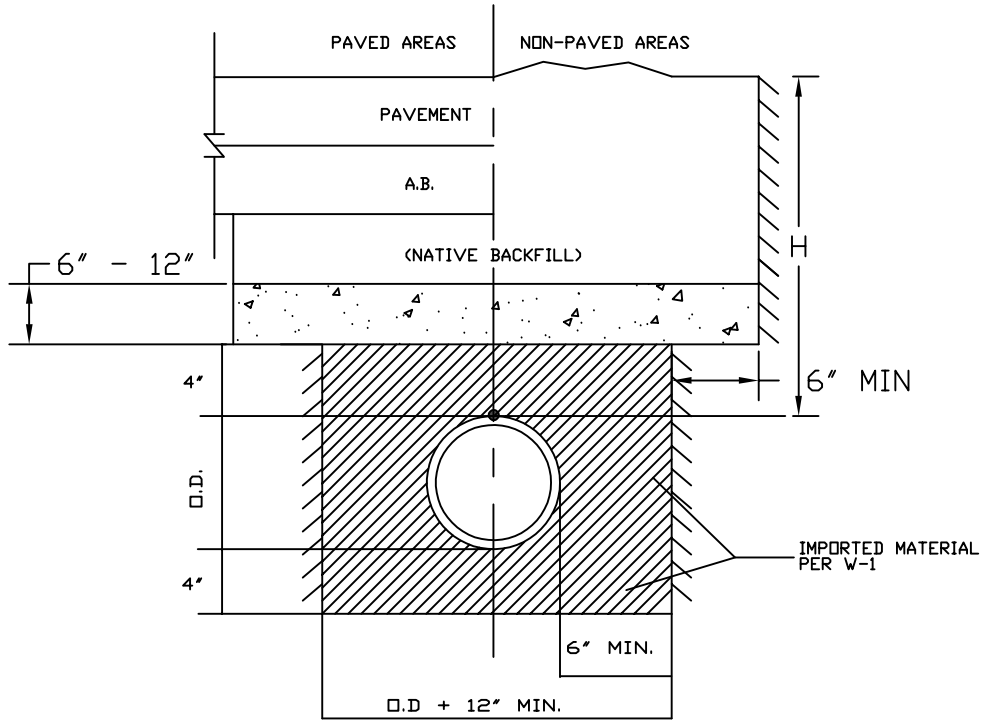

CONCRETE CAP

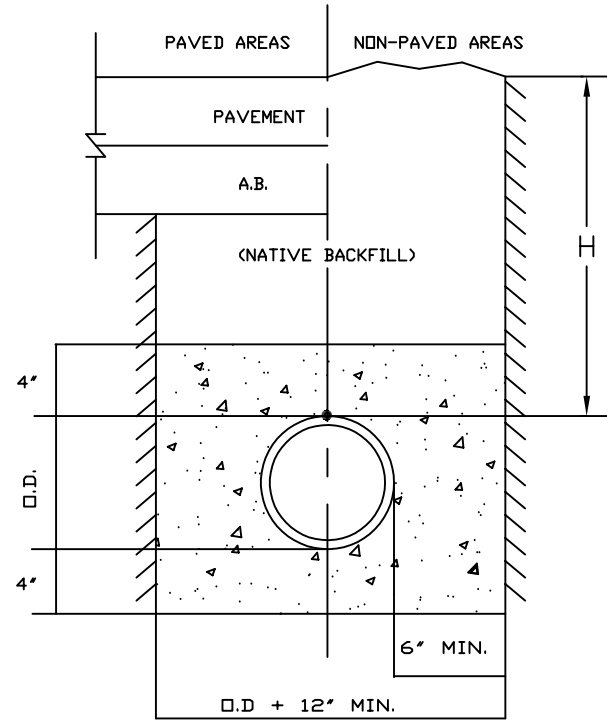

CONCRETE ENCASEMENT

APPLICATION:

- WHERE $30'' < H < 36''$, USE DIP ONLY
- WHERE $20'' < H < 30''$
 - WITH SERVICES, USE DIP AND CONCRETE CAP
 - WITHOUT SERVICES, USE DIP AND CONCRETE ENCASE (WRAP DIP IN 1/2" CLOSED CELL FOAM PRIOR TO ENCASEMENT)
- WHERE $H < 20''$, REDESIGN WATERLINE

NOTE:

THIS DETAIL SHALL BE USED ON A CASE-BY-CASE BASIS WITH THE APPROVAL OF THE EUD DIRECTOR. IN MOST CASES, THE 36" MINIMUM COVER SHALL PREVAIL.

Richard D. Plecker

RICHARD PLECKER
ENVIRONMENTAL UTILITIES DIRECTOR



ENVIRONMENTAL UTILITIES
DEPARTMENT

SHALLOW WATER MAINS

SCALE: NONE
REVISED: JANUARY 2017
DRAWN BY: R. VAN NESS
APPROVED BY: RICHARD PLECKER

W-23

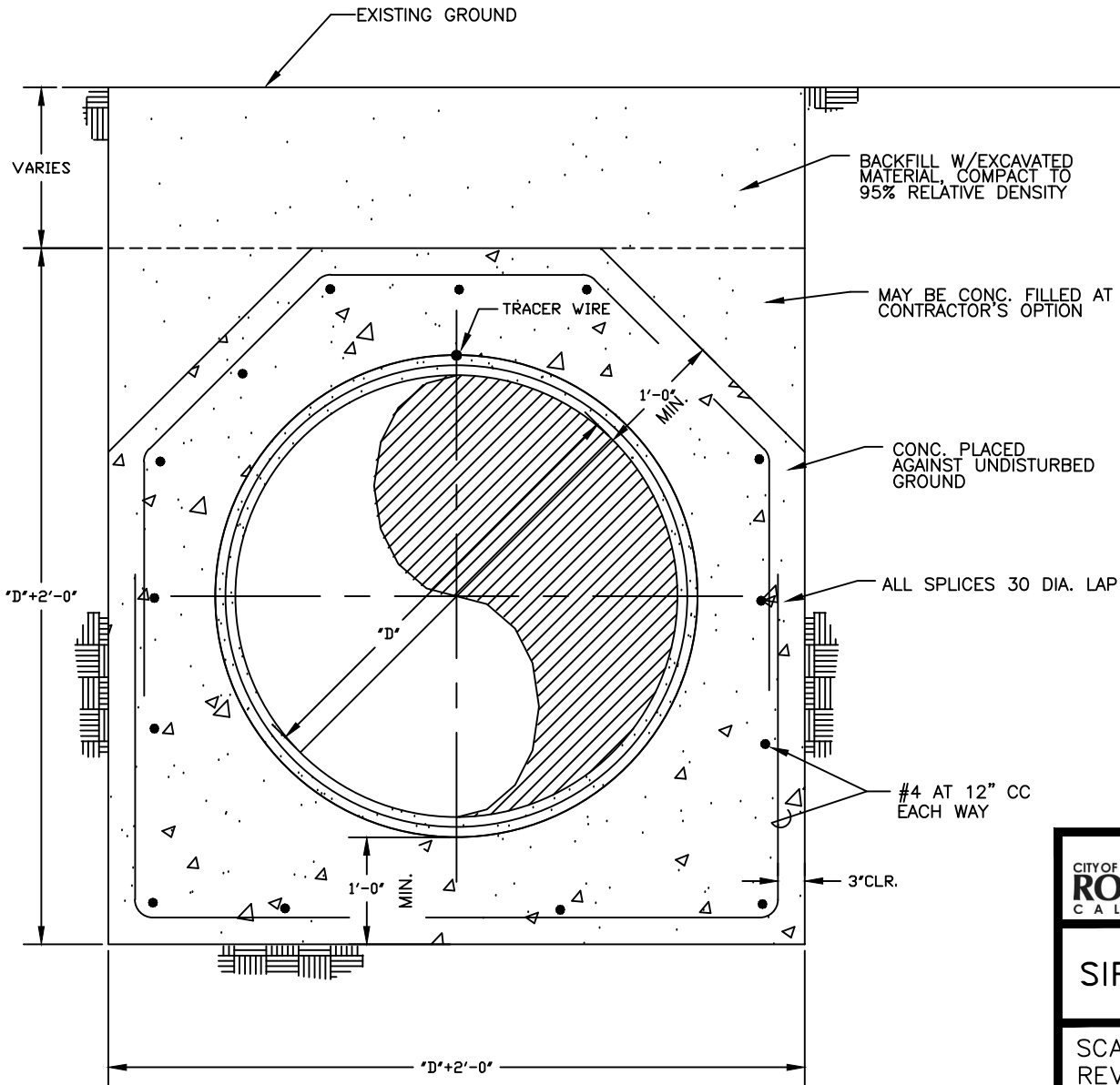

NOTES:

1. RESTRAINED PIPE WITHIN CASINGS OR BRIDGES SHALL BE FULLY EXTENDED OR "STRETCHED OUT" TO REMOVE THE SLACK BETWEEN THE JOINTS THE ENTIRE LENGTH OF THE STRUCTURE.

Richard D. Plecker

RICHARD PLECKER
ENVIRONMENTAL UTILITIES DIRECTOR



ENVIRONMENTAL UTILITIES
DEPARTMENT

SIPHON CONCRETE ENCASEMENT

SCALE: NONE
REVISED: JANUARY 2020
DRAWN BY: R. VAN NESS
APPROVED BY: RICHARD PLECKER

W-24

GMI Cover and Frame Assembly

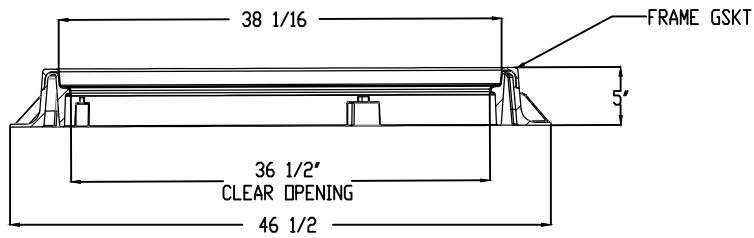
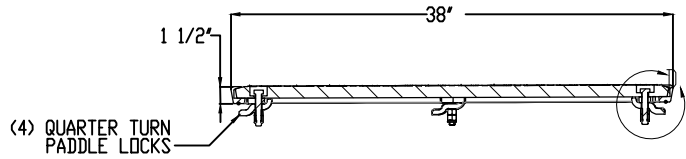

SECTION A-A

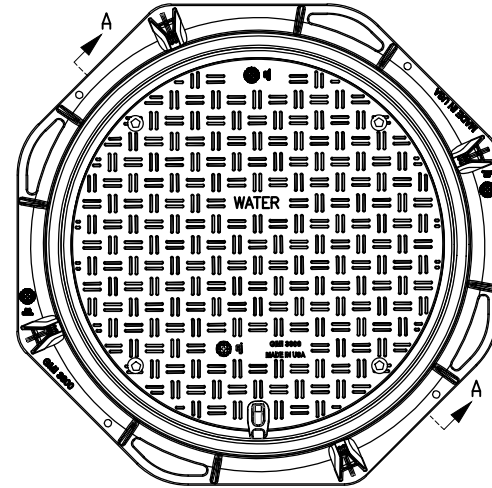
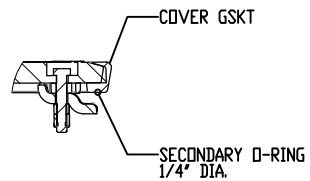

Richard D. Plecker

RICHARD PLECKER
ENVIRONMENTAL UTILITIES DIRECTOR

CITY OF
ROSEVILLE
CALIFORNIA

ENVIRONMENTAL UTILITIES
DEPARTMENT

36" MANHOLE RING AND COVER

SCALE: NONE
REVISED: JANUARY 2017
DRAWN BY: R. VAN NESS
APPROVED BY: RICHARD PLECKER

W-25

NOTES:

TO CONFORM TO AASHTO M306-05, H-20 AND H-25 EN/24 D4000.

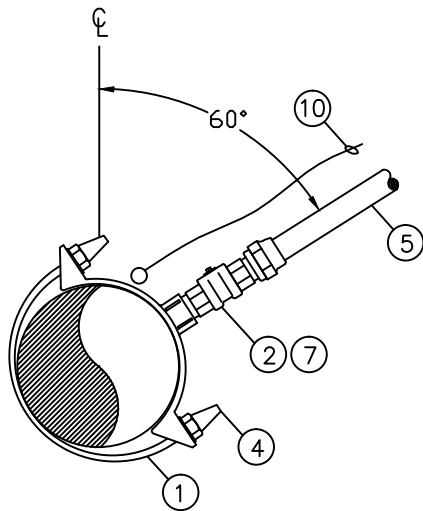

DOUBLE STRAP
DUCTILE IRON PIPE SADDLE

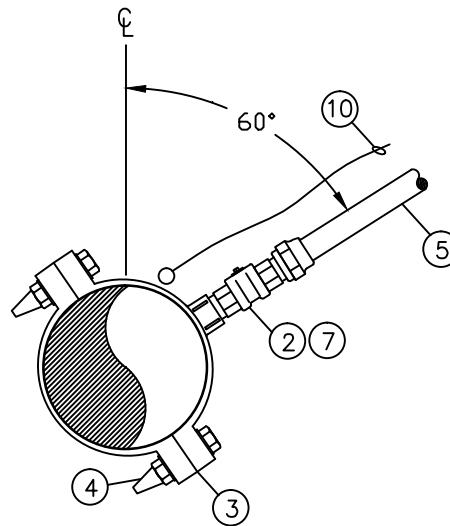

PVC PIPE SADDLE

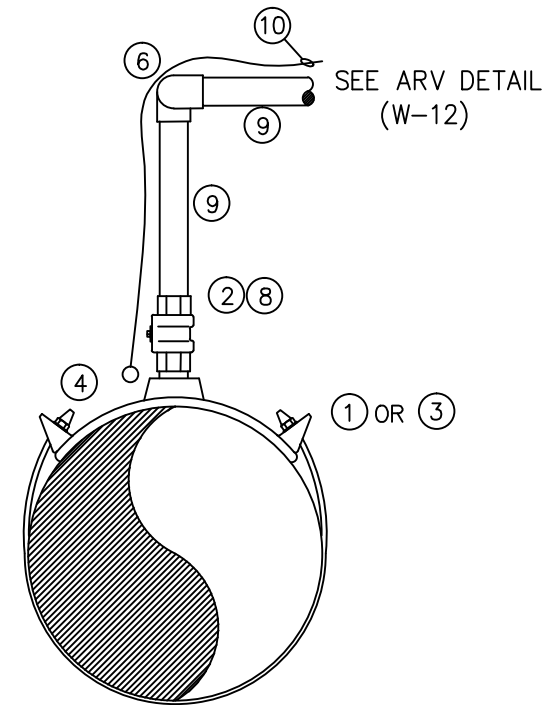

ARV SADDLE

MATERIALS:

- 1.) DOUBLE STRAP BRASS SADDLE FOR DUCTILE IRON MAIN
- 2.) INSULATING CORPORATION STOP OR NON INSULATED CORPORATION STOP WITH NYLON BUSHING
- 3.) BRASS SADDLE FOR PVC MAIN
- 4.) ZINC CAPS ON ALL BOLTS (ONLY WITH NON-INSULATED CORPORATION STOP)
- 5.) COPPER SERVICE
- 6.) SWING JOINT (2 - 90° BRASS FITTINGS)
- 7.) CORP STOP W/COMPRESSION COUPLING
- 8.) CORP STOP W/THREADED COUPLING
- 9.) THREADED BRASS PIPE
- 10.) TRACING WIRE (FOR COMMERCIAL SERVICES ONLY)

NOTES:

WRAP CORPORATION STOP AND COPPER SERVICE A MINIMUM OF 3' WITH AN APPROVED DIELECTRIC TAPE AND POLYKEN PRIMER PER MANUFACTURER'S RECOMENDATIONS.

SADDLES SHALL BE WRAPPED IN 8 MIL POLYETHYLENE AND BACKFILLED WITH SAND.

TRACING WIRE SHALL BE REQUIRED ON ARV, HYDRANT RUNS, BLOW OFFS, SERVICES WITHOUT CONTINUOUS COPPER PIPE, AND OTHER MAJOR APPURTENANCES.

Richard D. Plecker

RICHARD PLECKER
ENVIRONMENTAL UTILITIES DIRECTOR



ENVIRONMENTAL UTILITIES
DEPARTMENT

SADDLE DETAIL

SCALE: NONE
REVISED: JANUARY 2016
DRAWN BY: R. VAN NESS
APPROVED BY: RICHARD PLECKER

W-26

CURB STAMPED "W"
AT SERVICE LOCATION

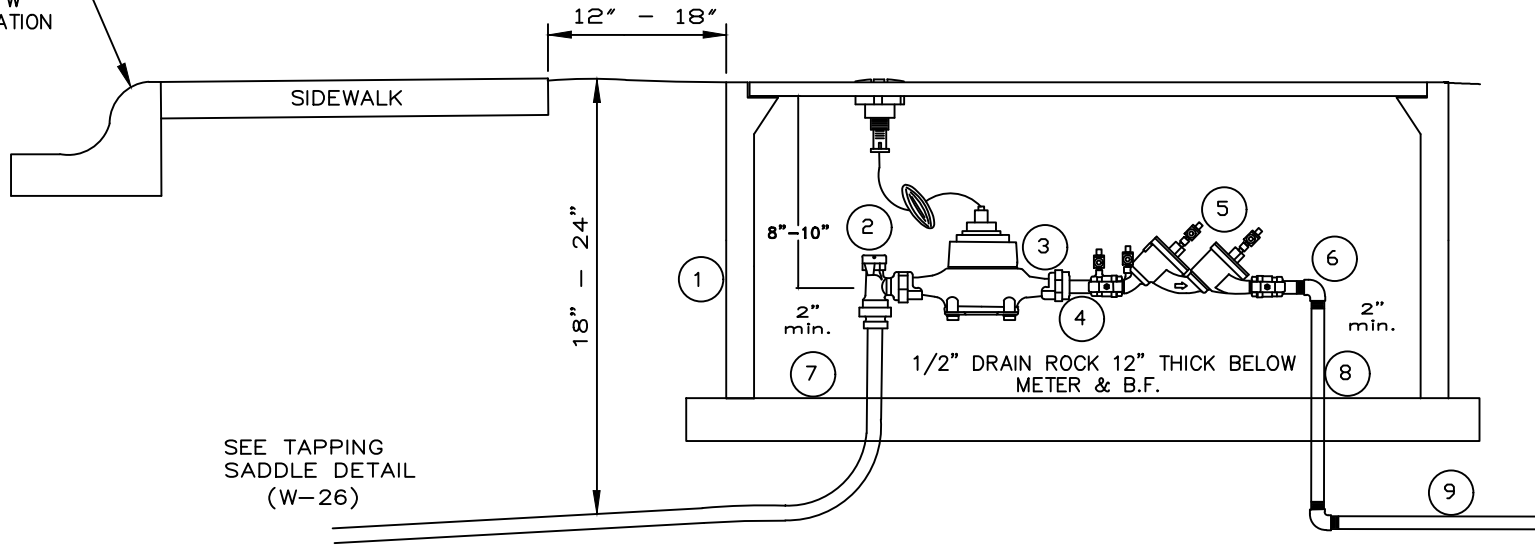

SEE TAPPING
SADDLE DETAIL
(W-26)

NOTES:

WATER METERS SHALL BE PURCHASED THROUGH THE CITY
PURCHASE INCLUDES INSTALLATION.

INSTALL CONCRETE BLOCKING (4"x4"x 15 1/2" SOLID SLUMP BLOCK)
UNDER ENTIRE UTILITY BOX PERIMETER.

BURIED PIPE AND FITTINGS SHALL BE WRAPPED WITH 8 MIL
POLYETHYLENE OR APPROVED EQUAL.

- 1) N 36 UTILITY BOX
- 2) ANGLED METER VALVE W/PADLOCK WINGS (PACK JOINT)
- 3) WATER METER (PURCHASED THROUGH CITY)
- 4) 4" BRASS NIPPLE
- 5) DOUBLE CHECK VALVE (WATTS SERIES 719)
- 6) STREET "L" (BRASS)
- 7) 3" X 5" CONCRETE BRICK
UNDER ENTIRE PERIMETER OF BOX.
- 8) 12" BRASS NIPPLE
- 9) 18" BRASS NIPPLE (MIN.)

Richard D. Plecker

RICHARD PLECKER
ENVIRONMENTAL UTILITIES DIRECTOR



ENVIRONMENTAL UTILITIES
DEPARTMENT

DUAL WATER USE (POTABLE)
3/4" & 1" SERVICE LINE

SCALE: NONE
REVISED: JANUARY 2017
DRAWN BY: R. VAN NESS
APPROVED BY: RICHARD PLECKER

W-27

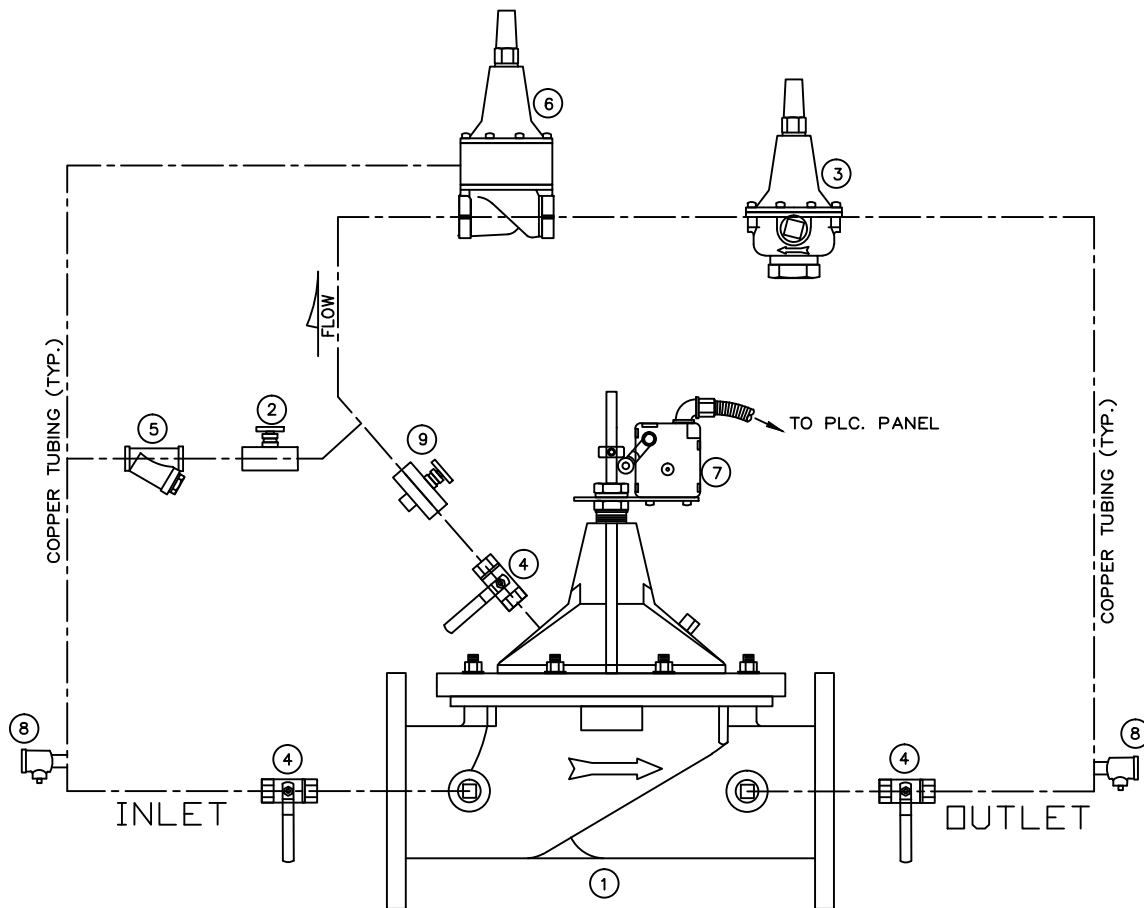

- 1) MAIN VALVE, STAINLESS STEEL BODY, AMES, CLA VAL
- 2) NEEDLE VALVE, DELTRO
- 3) PRESSURE REDUCING CONTROL, AMES CP-15,
- 4) BALL VALVES, APOLLO OR HOKE
- 5) "Y" STRAINER WITH BRASS PLUG 1/4"NPT
- 6) PRESSURE SUSTAINING VALVE, AMES CP-16,
- 7) OPEN LIMIT SWITCH, MICROSWITCH
- 8) TEST COCK, MIPT 1/4" BRASS
- 9) OPENING SPEED CONTROL, DELTRO

Richard D. Plecker

RICHARD PLECKERD
ENVIRONMENTAL UTILITIES DIRECTOR

NOTES:

CITY APPROVED GATE VALVES SHALL BE PLACED UP AND DOWN STREAM OF MAIN VALVE.

FITTINGS SHALL BE BRASS COMPRESSION TYPE



ENVIRONMENTAL UTILITIES
DEPARTMENT

COMBINATION PRESSURE REDUCING AND
PRESSURE SUSTAINING VALVE

SCALE: NONE
REVISED: JANUARY 2016
DRAWN BY: R. VAN NESS
APPROVED BY: RICHARD PLECKER

W-28

NOTES:

- PIPE SHALL BE DUCTILE IRON FOR 3" AND LARGER.
- INSTALL (3" X 5") CONCRETE BRICK UNDER ENTIRE PERIMETER OF THE UTILITY BOX.
- PIPE AND FITTINGS SHALL BE WRAPPED WITH 8 MIL. POLYETHYLENE
- USE CITY APPROVED RESTRAINED JOINTS OR FLANGED SPOOLS
- WATER METER SHALL BE PURCHASED THROUGH THE CITY. PURCHASE INCLUDES INSTALLATION.
- USE TURBO METER FOR IRRIGATION & COMPOUND METER FOR COMMERCIAL SERVICE.

TO BACKFLOW
SEE DETAIL
W-8

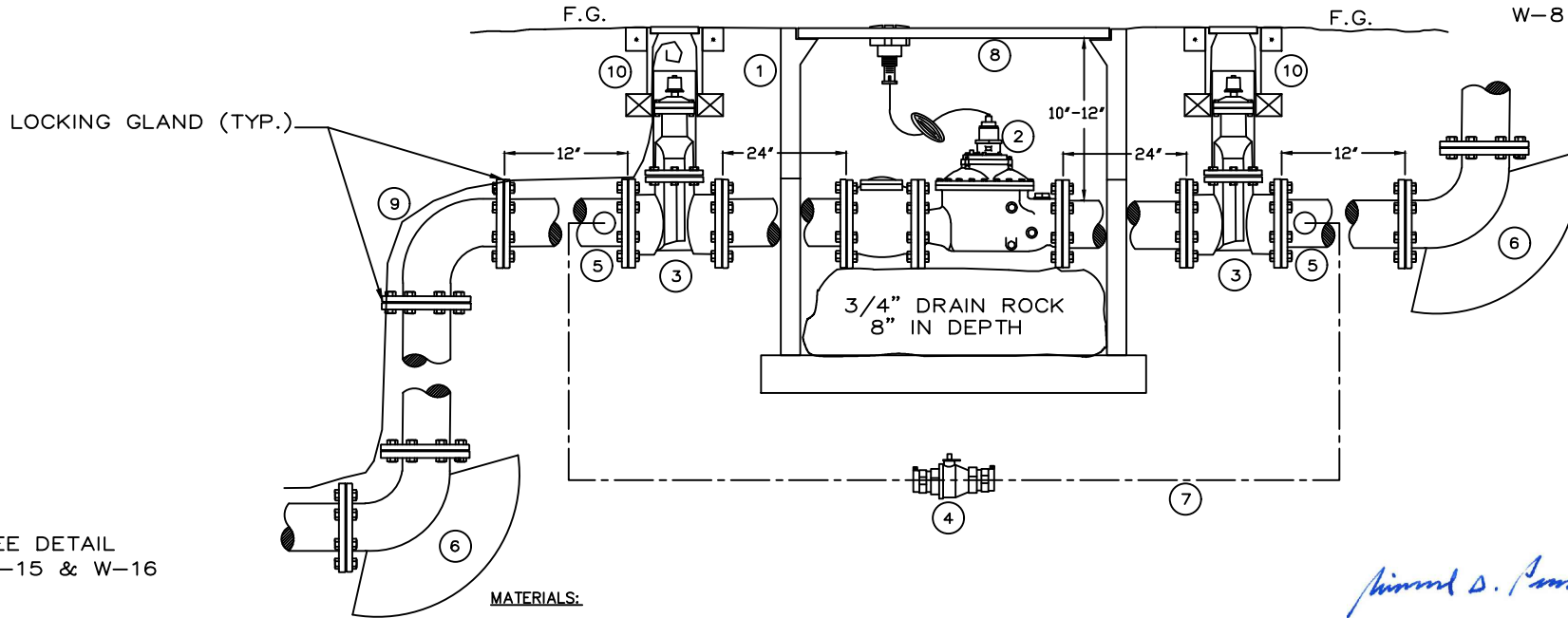

MATERIALS:

- 1) REFER TO METER TABLE IN SECTION 81-16 FOR UTILITY BOX SIZING. WITH EXTENSION. MORTAR EXTENSION JOINT INSIDE AND OUT.
- 2) METER WITH STRAINER (PURCHASED THROUGH CITY)
INSTALL IDLER SPOOL DURING INSTALLATION OF METER BOX.
- 3) RESILENT SEAT GATE VALVE (3"-6")
- 4) 2" LOCKING CURB STOP IN G-5 BOX
- 5) 2" DOUBLE STRAP BRASS SADDLE FOR DUCTILE IRON MAIN WITH 2" MIPT BY COMPRESSION ADAPTER
- 6) THRUST BLOCKS (TYP.)
- 7) 2" BYPASS PIPE MATERIAL TO BE SOFT COPPER TYPE K (STICK NOT ROLLED COPPER) AND FITTINGS TO BE BRASS COMPRESSION TYPE.
- 8) METAL TRAFFIC LID WELD MARKED "RSVL WATER"
- 9) TRACING WIRE
- 10) SEE W-16 FOR VALVE BOX AND RISER DETAIL

Richard D. Plecker

RICHARD PLECKER
ENVIRONMENTAL UTILITIES DIRECTOR

PLAN VIEW:
METER BYPASS

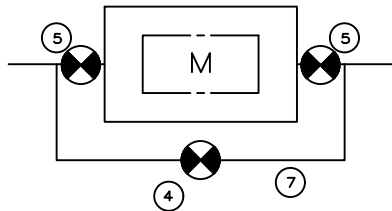

ENVIRONMENTAL UTILITIES
DEPARTMENT

3", 4", 6", 8" COMPOUND &
TURBO METER WITH BYPASS

SCALE: NONE
REVISED: JANUARY 2023
DRAWN BY: J. THOMPSON
APPROVED BY: RICHARD PLECKER

W-29

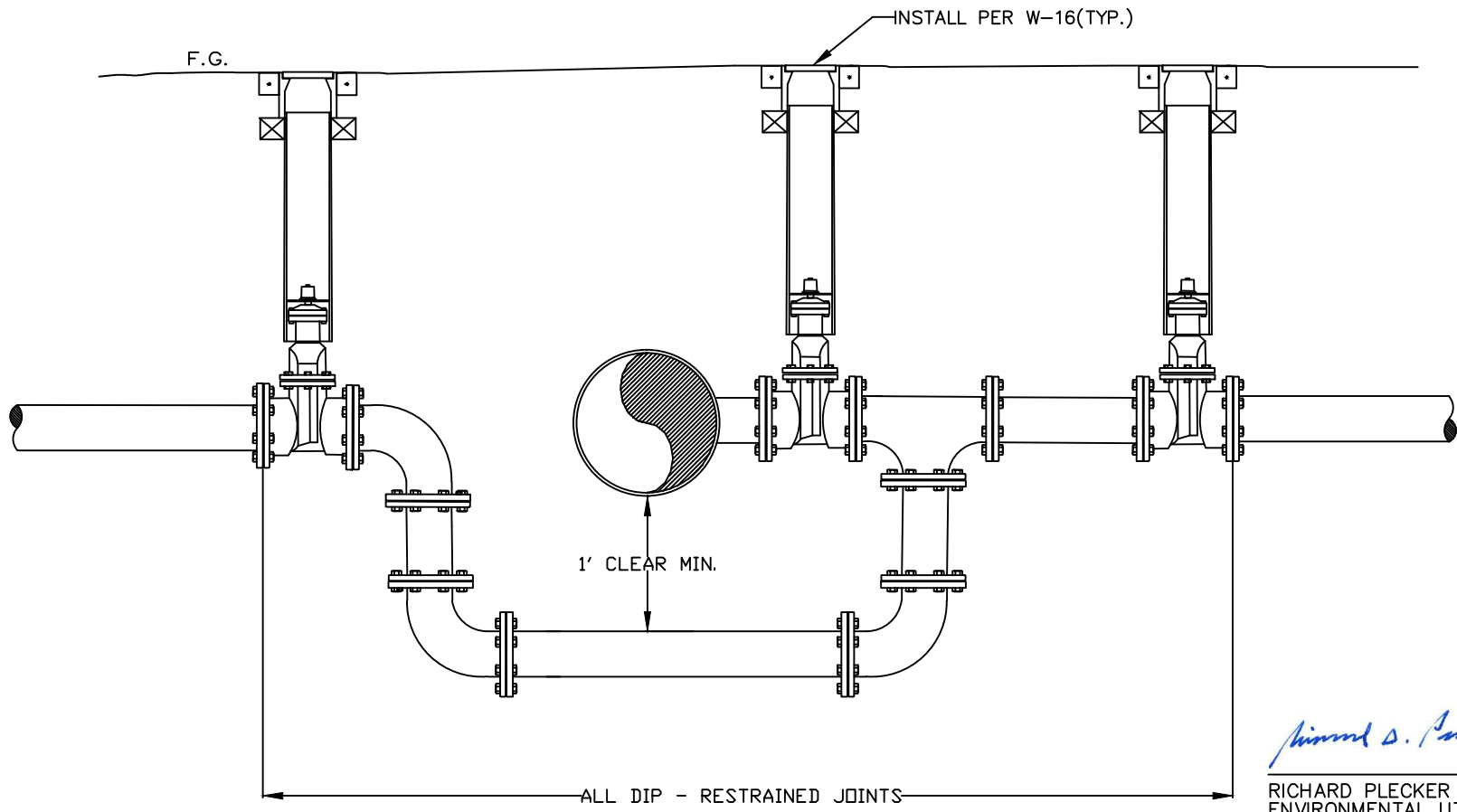

Richard D. Plecker

RICHARD PLECKER
ENVIRONMENTAL UTILITIES DIRECTOR

CITY OF  ENVIRONMENTAL UTILITIES DEPARTMENT

FLOW THRU DETAIL

SCALE: NONE
 REVISED: JANUARY 2016
 DRAWN BY: R. VAN NESS
 APPROVED BY: RICHARD PLECKER

W-30

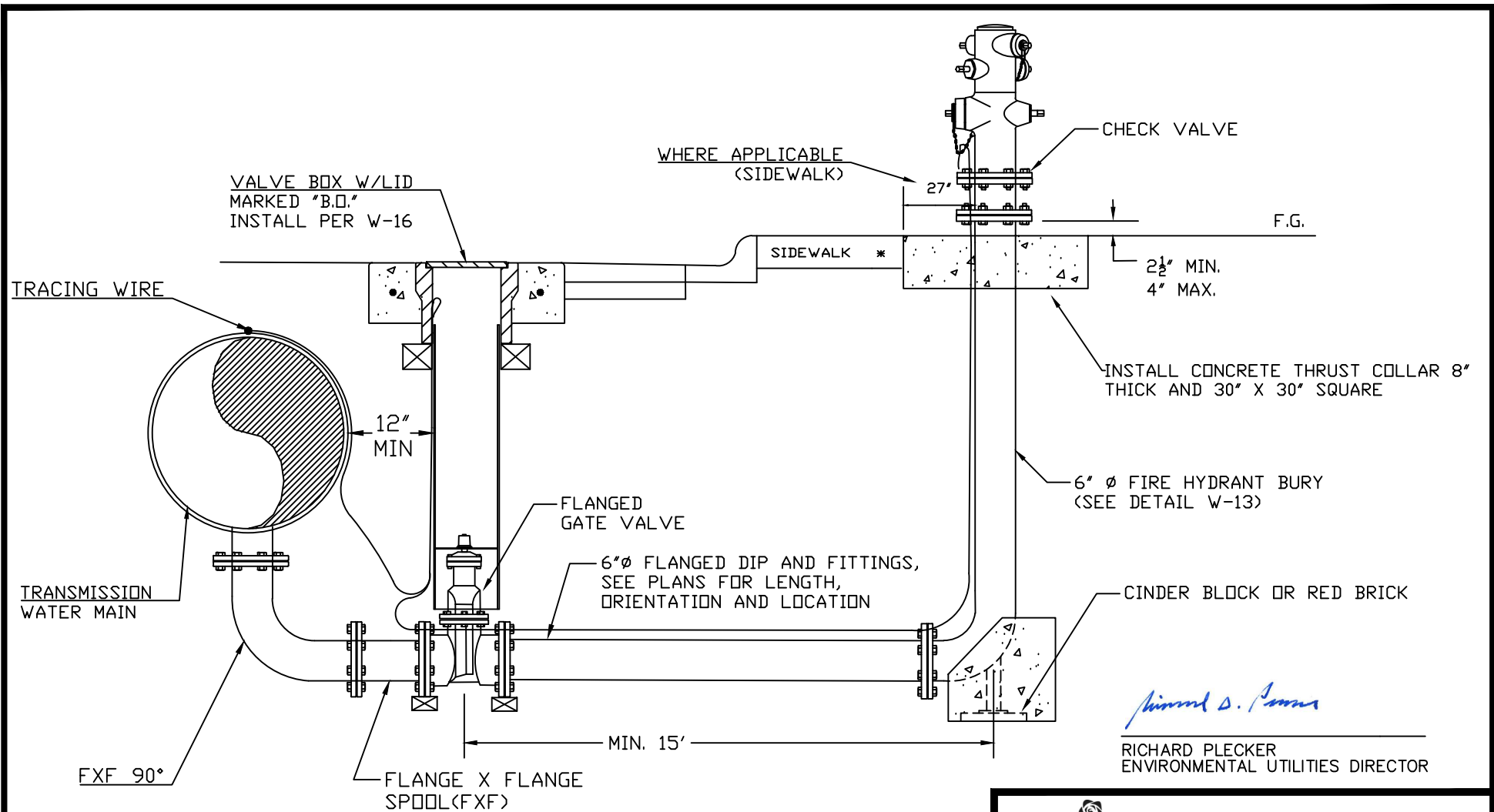

NOTES:

1. STATION LOCATIONS SHOWN ON PLANS ARE APPROXIMATE. PLACE BLOW-OFFS ADJACENT TO LOW POINT IN MAIN LINE.
2. ALL FITTINGS SHALL BE DIP.
3. ENTIRE LENGTH TO BE RESTRAINED.
4. CONTRACTOR HAS THE OPTION OF USING MECHANICAL JOINT (MJ) FITTING. IF MJ FITTINGS ARE USED, MEGALUGS SHALL BE INSTALLED.
5. CONCRETE INSTALLED FOR STABILITY.

	ENVIRONMENTAL UTILITIES DEPARTMENT
TRANSMISSION MAIN HYDRANT BLOW OFF	
SCALE: NONE REVISED: JANUARY 2023 DRAWN BY: J. THOMPSON APPROVED BY: RICHARD PLECKER	
W-32	

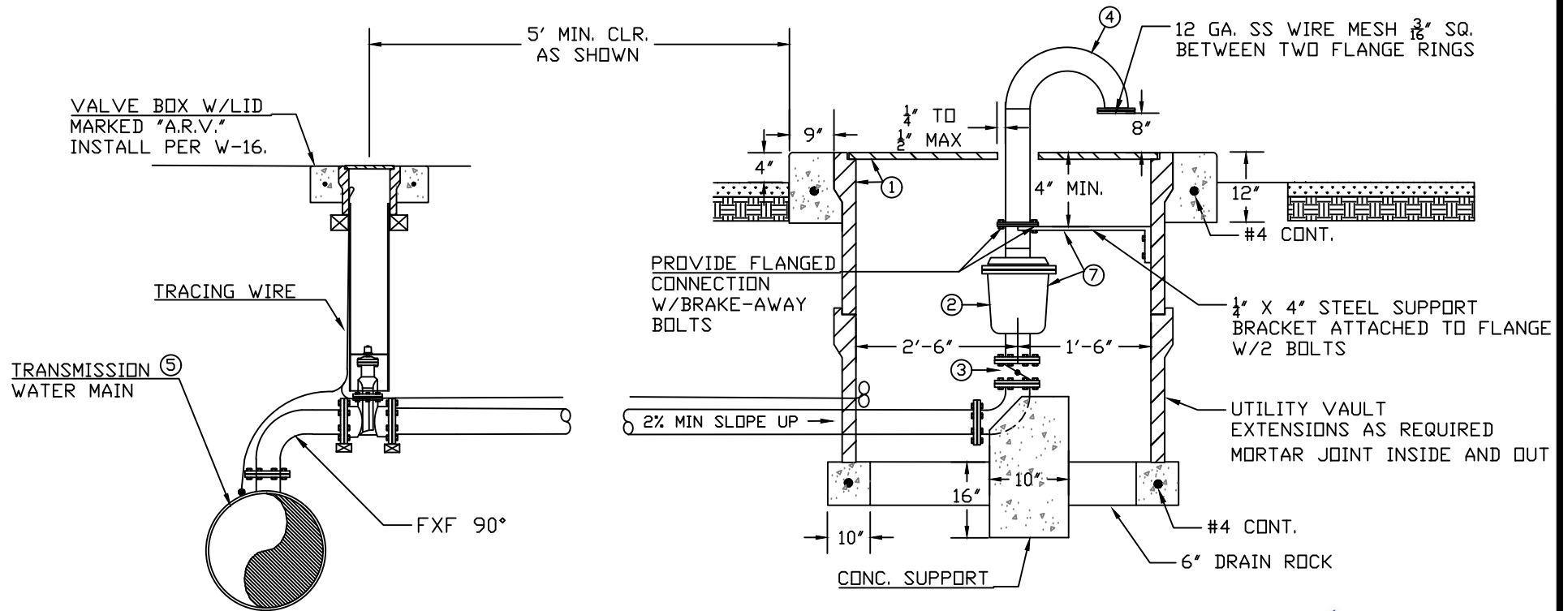

Richard D. Plecker

RICHARD PLECKER
ENVIRONMENTAL UTILITIES DIRECTOR

NOTES:

1. PRECAST CONC. UTILITY BOX (48"X48" I.D.) WITH GALV. STEEL LID CHECKERED PLATE COVER (2 PIECE SPLIT LID, DESIGNED FOR H2O LOADING) MARKED "RSVL A.R.V." (USE SS HOLD DOWN SCREWS).
2. COMBINATION AIR/VACUUM RELEASE VALVE, PIPING, AND FITTINGS SIZED AS SHOWN ON PLAN & PROFILE SHEETS. (VALVE SHALL BE FLANGED)
3. FLANGED BUTTERFLY VALVE WITH HAND WHEEL OPERATOR.
4. WSP VENT, SCH 40, GALV. AFTER FABRICATION.
5. ARV TO BE PLACED AT HIGH POINT OF PIPE AT SIDE OUTLET FLANGE.
6. RESTRAIN ALL JOINTS BETWEEN C.C.P. AND ARV. RESTRAINED MJ WITH MEGALUG GLANDS MAY BE USED IN LUE OF FLANGED FITTINGS BEYOND G.V.
7. EXPOSED NON-GALVANIZED PIPING, VALVES, AND APPUR. SHALL BE PAINTED WITH TWO PRIMER AND TWO FINISH COATS OF MACHINERY ENAMEL (COLOR TO BE SELECTED BY EUD)
8. ALL BURIED PIPE, FITTINGS, VALVES AND APPUR. SHALL BE DUCTILE IRON AND ENCASED WITH 8 MIL. POLYETHYLENE.
9. CONCRETE INSTALLED FOR STABILITY.



ENVIRONMENTAL UTILITIES
DEPARTMENT

3" THROUGH 6" ARV

SCALE: NONE
REVISED: JANUARY 2020
DRAWN BY: R. VAN NESS
APPROVED BY: RICHARD PLECKER

W-33

NOTES

- SEE VALVE BONDING DETAIL FOR ADDITIONAL REQUIREMENTS.

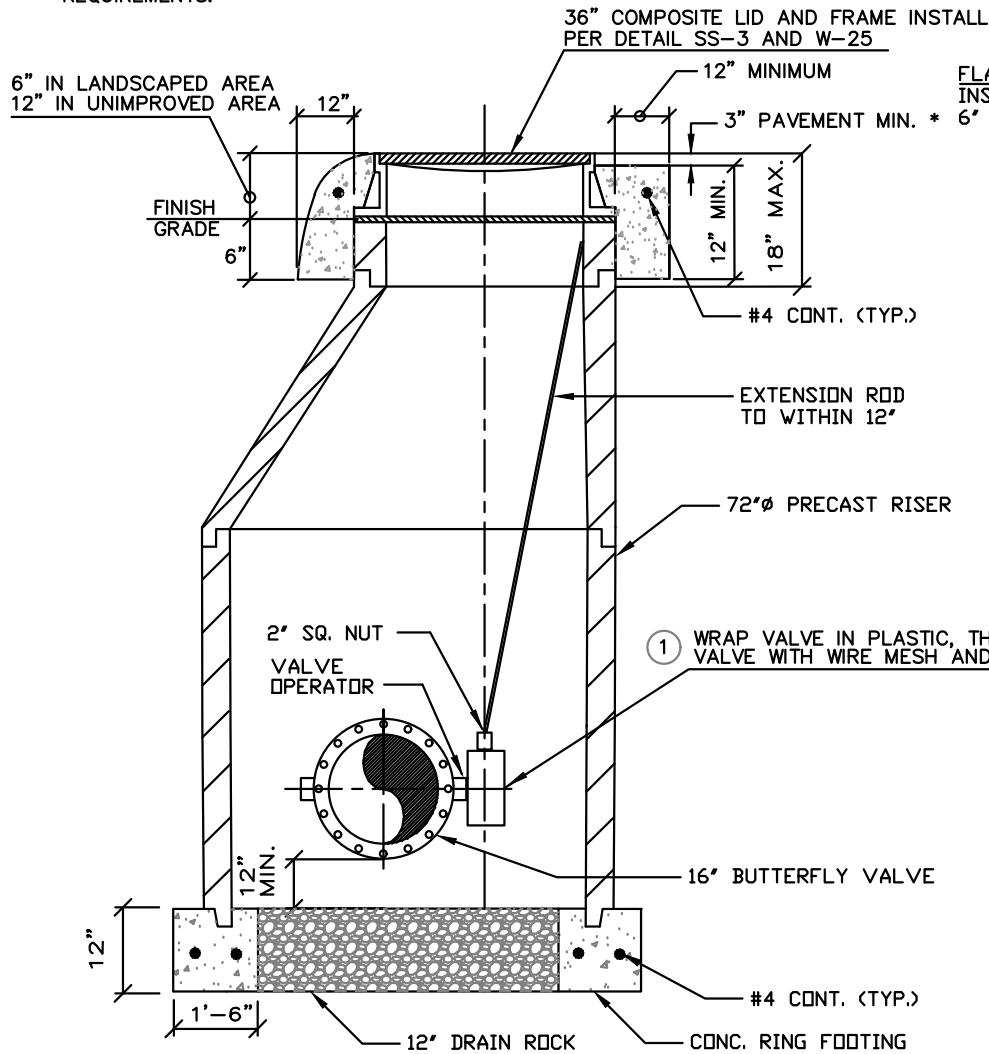

FLANGE TO BE INSTALLED A MIN. OF 6" FROM EDGE OF MH.

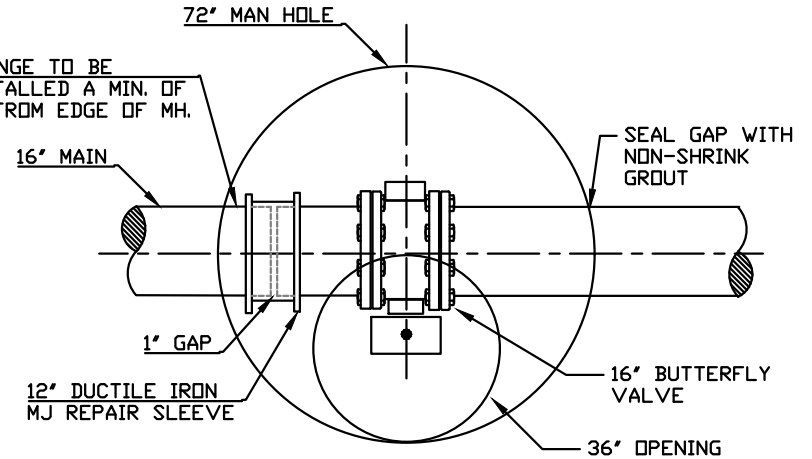

* NOTE: CONCRETE AROUND RIM SHALL BE BROUGHT TO FINISH GRADE FOR ALL COLLECTORS AND ARTERIALS, OPTIONAL IN ALL OTHER ROADWAYS. FINISH SURFACE SHALL BE MEDIUM FINISH WITH PATTERN PERPENDICULAR TO TRAVEL DIRECTION.

Richard D. Plecker

RICHARD PLECKER
ENVIRONMENTAL UTILITIES DIRECTOR



ENVIRONMENTAL UTILITIES
DEPARTMENT

16" MAINLINE VALVE ENCLOSURE

SCALE: NONE
REVISED: JANUARY 2023
DRAWN BY: J. THOMPSON
APPROVED BY: RICHARD PLECKER

W-34

NOTES

1. SEE VALVE BONDING DETAIL FOR ADDITIONAL REQUIREMENTS.

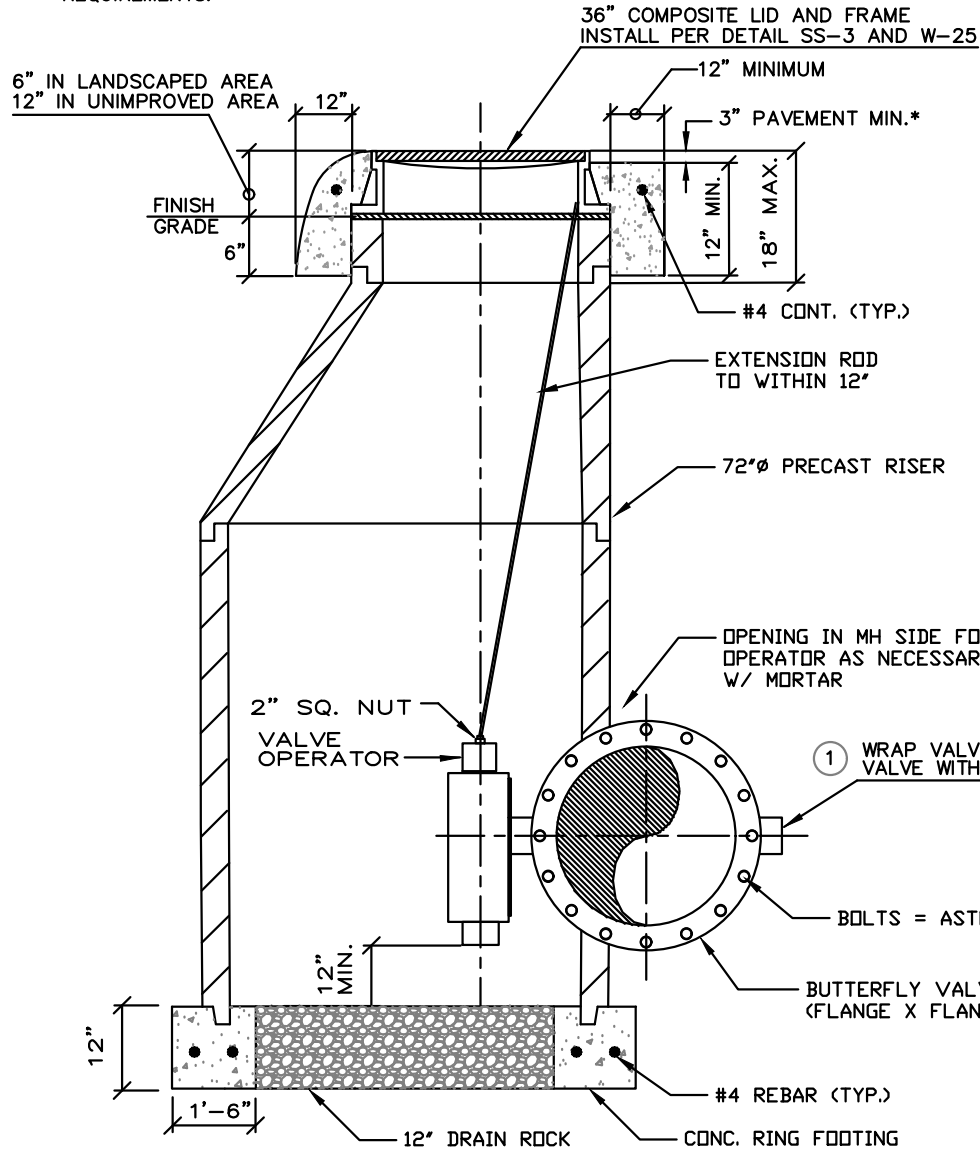

* NOTE: CONCRETE COLLAR SHALL BE PLACED FLUSH TO FINISH GRADE IN ALL COLLECTORS & ARTERIALS, OPTIONAL FOR ALL OTHER ROADWAYS. FINISH SURFACE SHALL BE MEDIUM BROOM FINISH WITH PATTERN PERPENDICULAR TO VEHICLE TRAVEL DIRECTION. SET COLLAR 1/8" BELOW ADJACENT FINISHED PAVEMENT.

① WRAP VALVE IN PLASTIC, THEN ENCASE VALVE WITH WIRE MESH AND MORTAR.

Richard D. Plecker

RICHARD PLECKER
ENVIRONMENTAL UTILITIES DIRECTOR



ENVIRONMENTAL UTILITIES
DEPARTMENT

24" & LARGER MAINLINE VALVE

SCALE: NONE
REVISED: JANUARY 2023
DRAWN BY: J. THOMPSON
APPROVED BY: RICHARD PLECKER

W-35

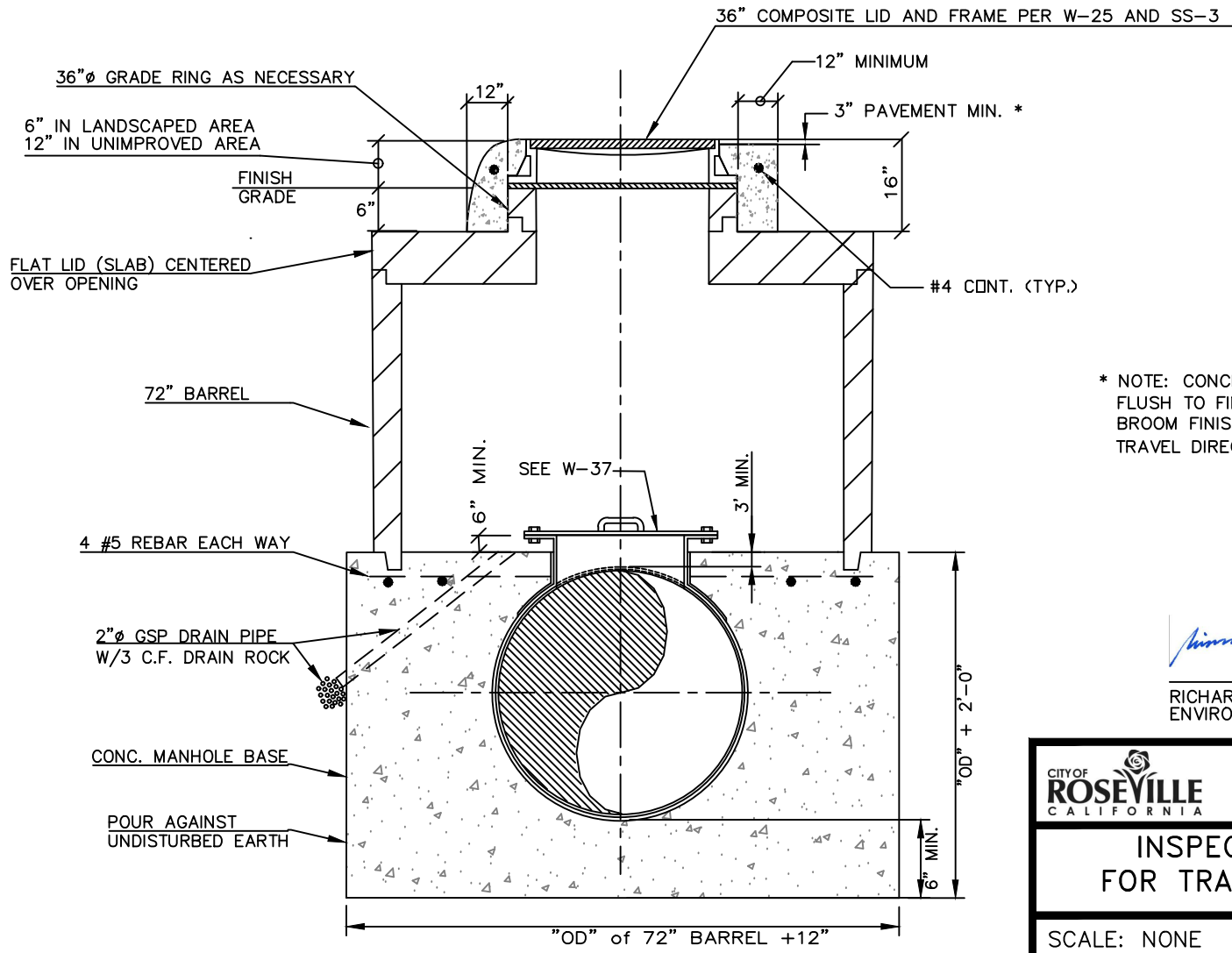

* NOTE: CONCRETE COLLAR MAY BE PLACED FLUSH TO FINISHED SURFACE WITH MEDIUM BROOM FINISH PERPENDICULAR TO VEHICLE TRAVEL DIRECTION.

Richard D. Plecker

RICHARD PLECKER
ENVIRONMENTAL UTILITIES DIRECTOR

	ENVIRONMENTAL UTILITIES DEPARTMENT
--	------------------------------------

INSPECTION MANHOLE FOR TRANSMISSION MAINS

SCALE: NONE
 REVISED: JANUARY 2018
 DRAWN BY: R. VAN NESS
 APPROVED BY: RICHARD PLECKER

W-36

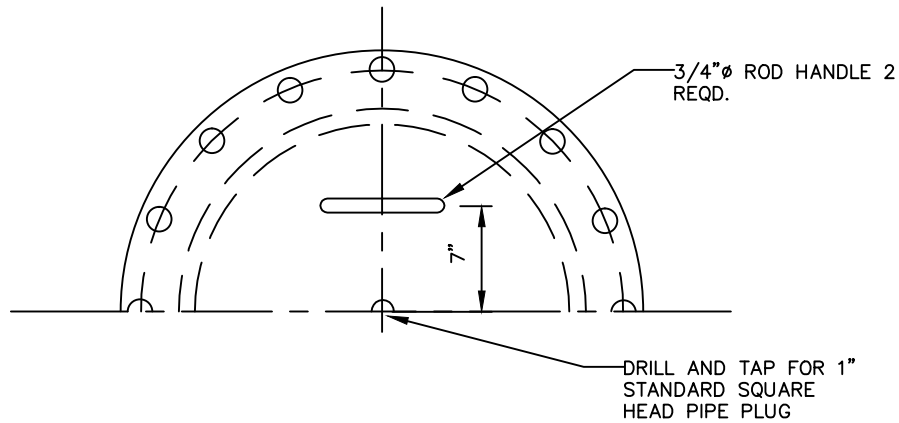

NOTES

CONSTRUCT MANHOLE PER AWWA C208 AND C303. DESIGN PRESSURE SHALL MEET OR EXCEED PIPELINE DESIGN PRESSURE.

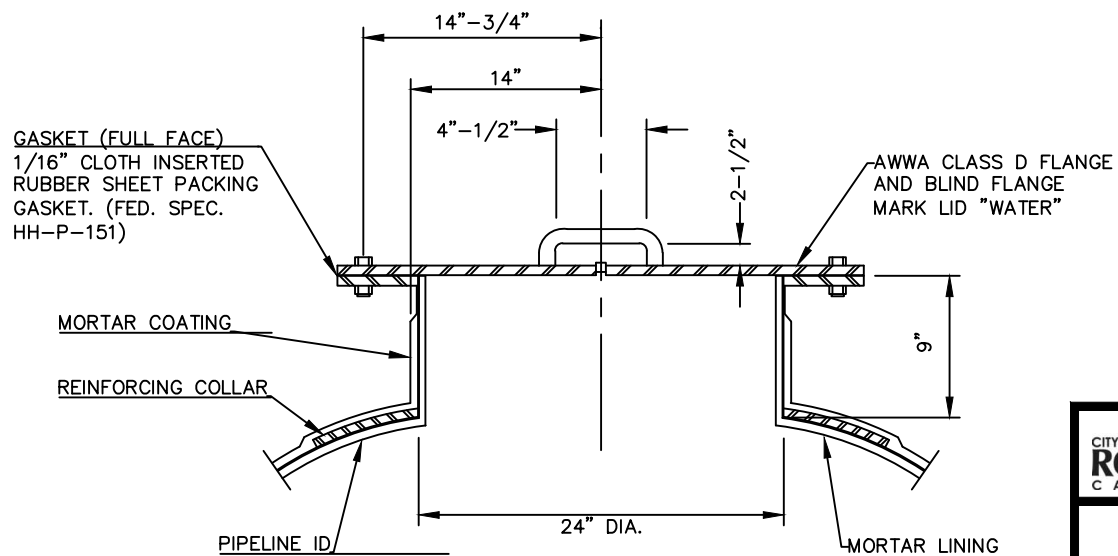

Richard D. Plecker

RICHARD PLECKER
ENVIRONMENTAL UTILITIES DIRECTOR



ENVIRONMENTAL UTILITIES
DEPARTMENT

**INSPECTION PORT
FOR TRANSMISSION MAINS**

SCALE: NONE
REVISED: JANUARY 2016
DRAWN BY: R. VAN NESS
APPROVED BY: RICHARD PLECKER

W-37

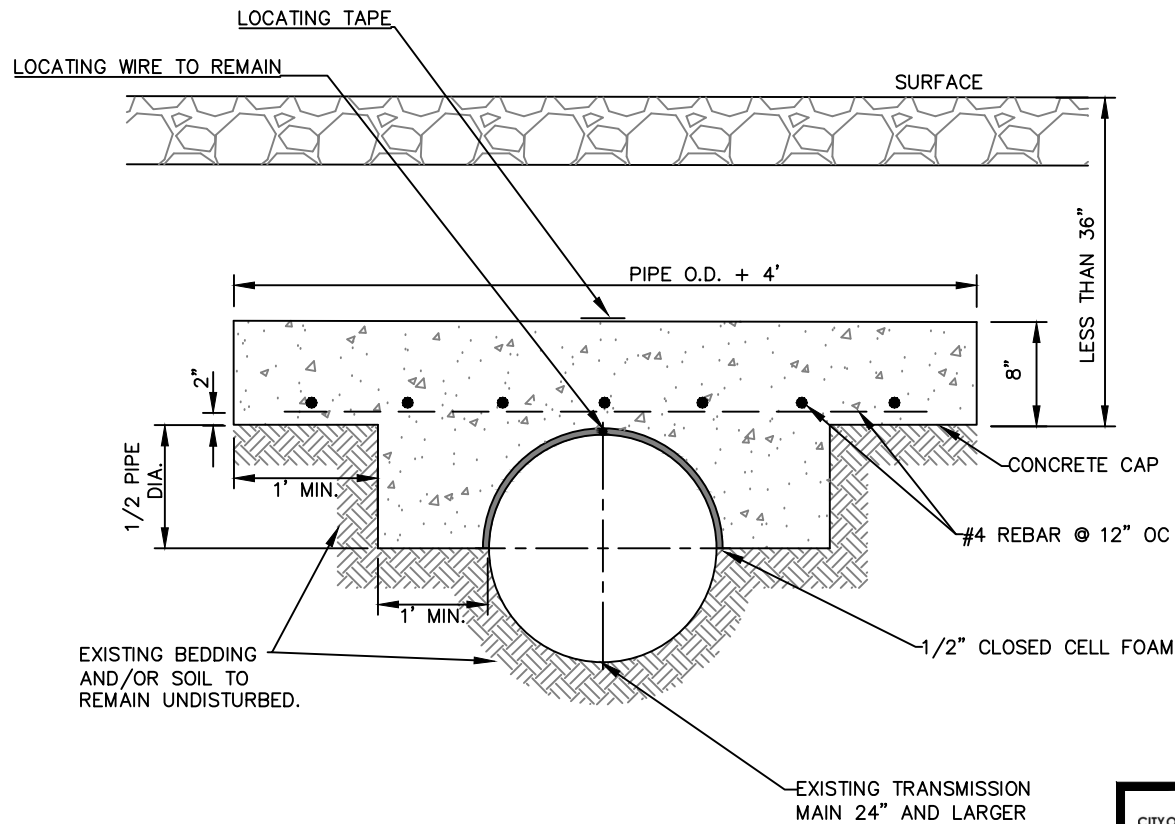

NOTES

1. CONCRETE CAP REQUIRED FOR ALL AREAS WITH LESS THAN 36" COVER
2. CONCRETE SHALL BE 5 SACK MIX MECHANICALLY TAMPED TO ELIMINATE VOIDS.

Richard D. Plecker

RICHARD PLECKER
ENVIRONMENTAL UTILITIES DIRECTOR



ENVIRONMENTAL UTILITIES
DEPARTMENT

**CONCRETE CAP ON SHALLOW
C.C.P. TRANSMISSION MAIN**

SCALE: NONE
REVISED: JANUARY 2019
DRAWN BY: R. VAN NESS
APPROVED BY: RICHARD PLECKER

W-38

NEW WATER MAIN PARALLEL CONSTRUCTION

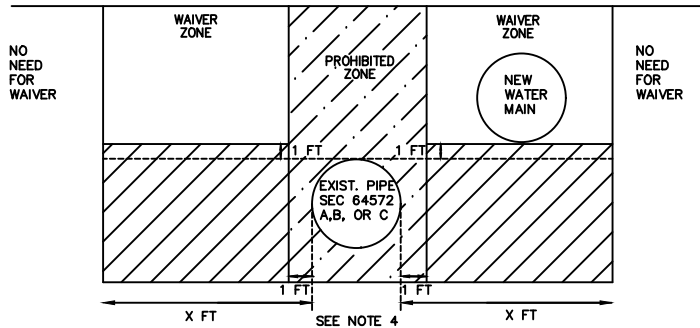

NEW WATER MAIN CROSSING CONSTRUCTION

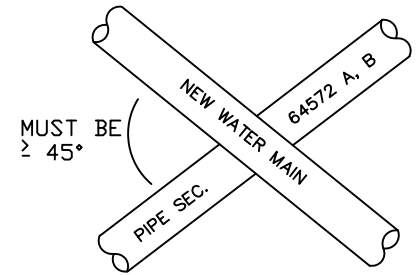
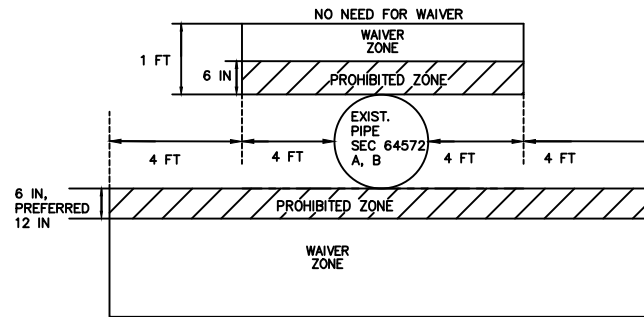

NEW PIPE SEC. 64572 (A), (B), (C) PARALLEL CONSTRUCTION

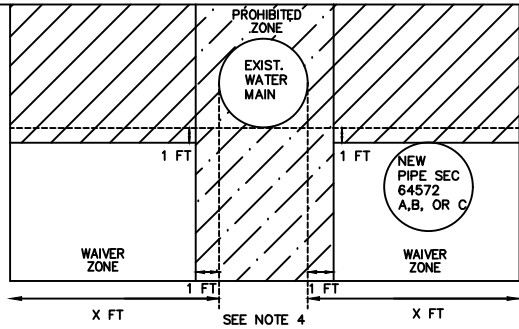

NEW PIPE SEC. 64572 (A), (B) CROSSING CONSTRUCTION

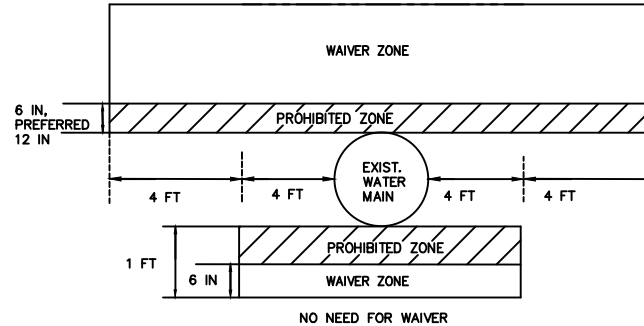

NOTES:

1. THE CONTRACTOR SHALL FOLLOW THE CITY OF ROSEVILLE STANDARDS AND THE CALIFORNIA CODE OF REGULATIONS (CCR) TITLE 22 SECTION 64572 WATER MAIN SEPARATION REQUIREMENTS. SEE CITY DESIGN STANDARDS SECTION 8-13.C FOR DDW WAIVER PROCESS.
2. PARALLEL PIPE INSTALLATION: NO WATER MAINS PARALLEL TO PIPELINES CONVEYING A FLUID LISTED IN CCR TITLE 22 SECTION 64572 SUBSECTIONS (A), (B), OR (C) SHALL BE INSTALLED WITHIN THE WAIVER ZONES WITHOUT SPECIAL APPROVAL FROM THE DDW.
3. DISTANCE X FT EQUALS 10 FT WHEN NON-WATER MAIN PIPELINE CONVEYS A FLUID LISTED IN CCR TITLE 22 SECTION 64572 SUBSECTION (A).
4. DISTANCE OF X FT EQUALS 5 FT (CITY OF ROSEVILLE DESIGN STANDARD SECTION 8-13.A) WHEN NON-WATER MAIN PIPELINE CONVEYS A FLUID LISTED IN CCR TITLE 22 SECTION 64572 SUBSECTION (B) OR (C).
 - a. SEPARATION DISTANCES BETWEEN 4 FT AND 5 FT REQUIRE CITY OF ROSEVILLE ENVIRONMENTAL UTILITIES DIRECTOR APPROVAL. SEPARATION DISTANCES LESS THAN 4 FT ALSO REQUIRE A DDW WAIVER.
5. PIPE CROSSING INSTALLATION: WHEN LOCATED IN THE WAIVER ZONE, THE WATER MAIN SHALL HAVE NO JOINTS WITHIN 8 HORIZONTAL FEET OF THE PIPE CROSSING CONVEYING FLUIDS CLASSIFIED IN CCR TITLE 22 SECTION 64572 SUBSECTIONS (A) AND (B). THE CONTRACTOR MUST WORK WITH THE CITY TO OBTAIN A WAIVER FROM THE DDW TO INSTALL WITHIN THE WAIVER ZONE.
6. NEW WATER MAINS AND NEW PIPELINES CONVEYING A FLUID LISTED IN CCR TITLE 22 SECTION 64572 SUBSECTION (A) SHALL NOT BE INSTALLED IN THE SAME TRENCH.

Rich Plecker

RICH PLECKER
ENVIRONMENTAL UTILITIES DIRECTOR

CITY OF ROSEVILLE ENVIRONMENTAL UTILITIES DEPARTMENT
CALIFORNIA

WATER MAIN AND SEWER MAIN CROSSING

SCALE: NONE
REVISED: JANUARY 2023
DRAWN BY: J. THOMPSON
APPROVED BY: R. PLECKER

W-39

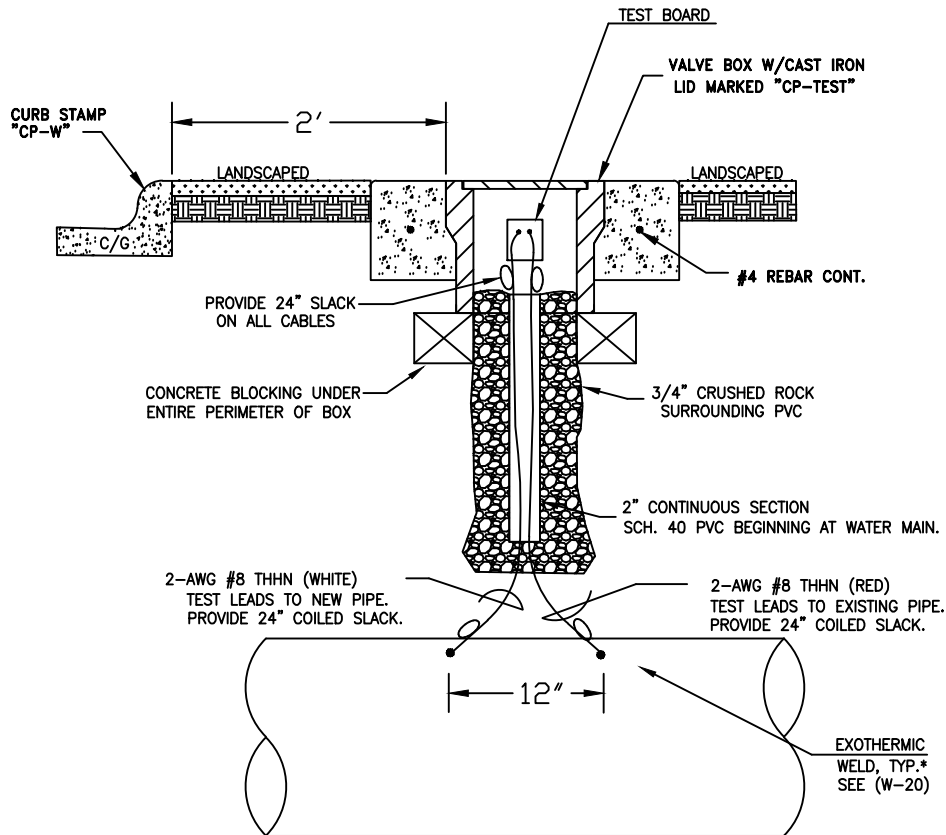

TEST STATION (TYPICAL)

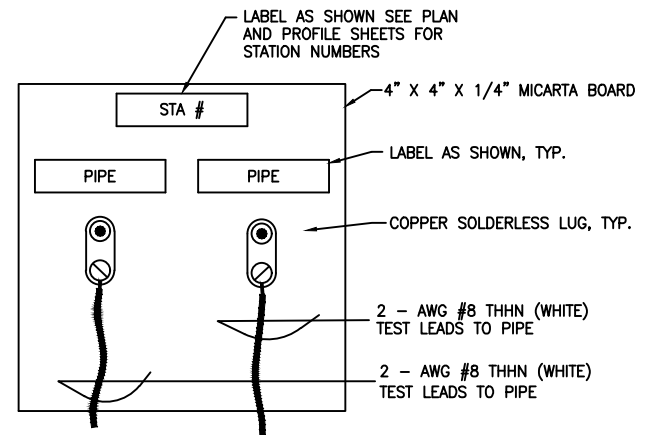

TEST STATION BOARD (TYPICAL)

Richard D. Samuelson

RICHARD PLECKER
ENVIRONMENTAL UTILITIES DIRECTOR



ENVIRONMENTAL UTILITIES
DEPARTMENT

TEST STATION

SCALE: NONE
REVISED: JANUARY 2019
DRAWN BY: D. SAMUELSON
APPROVED BY: RICHARD PLECKER

W-40

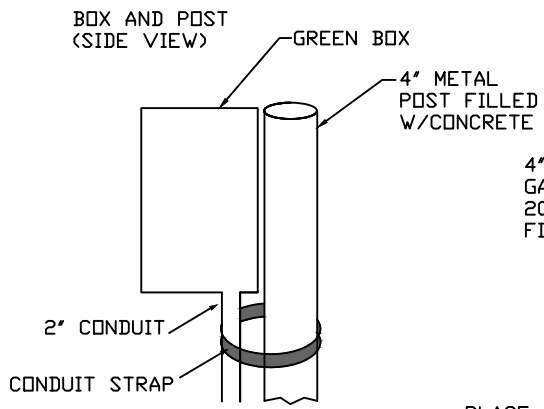

4" DIA. X 6" RIGID SCH. 80 GALVANIZED STEEL POST SET IN 20" DIA. X 24" DEEP CONCRETE. FILL POST WITH CONCRETE

2" DIA. RIGID GALVANIZED STEEL CONDUIT

- PLACE WIRES FROM WATER MAIN AND ANODE BAGS IN CONDUIT
- NUMBER WIRES (LABEL THEM)

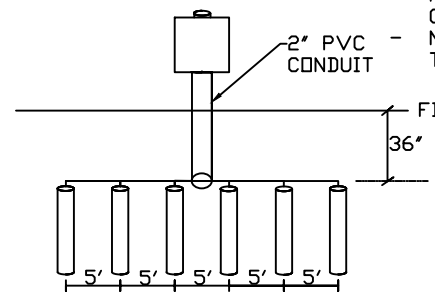

ANODE BAG CAPACITY TO BE DETERMINED BY DESIGNING ENGINEER AND APPROVED BY CITY.

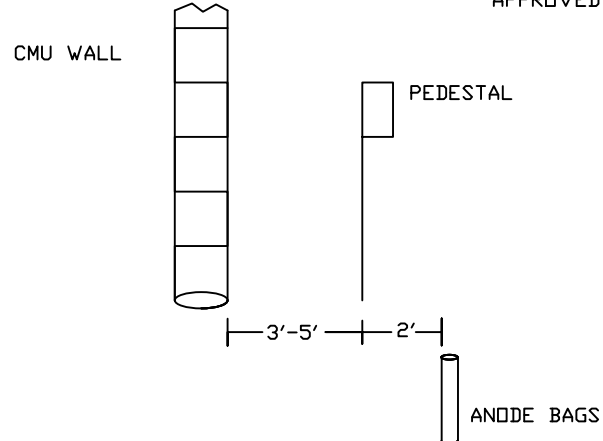

JUNCTION BOX SHALL BE LOCATED 3'-5' FROM SOUNDWALL

GALVANIC ANODE JUNCTION BOX SEE DETAILS

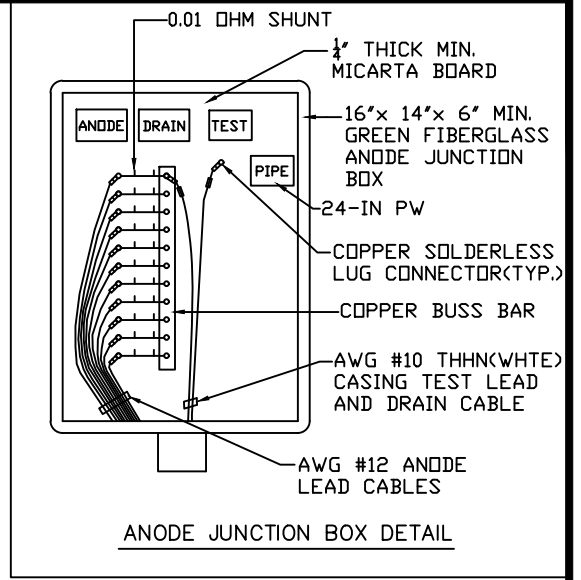
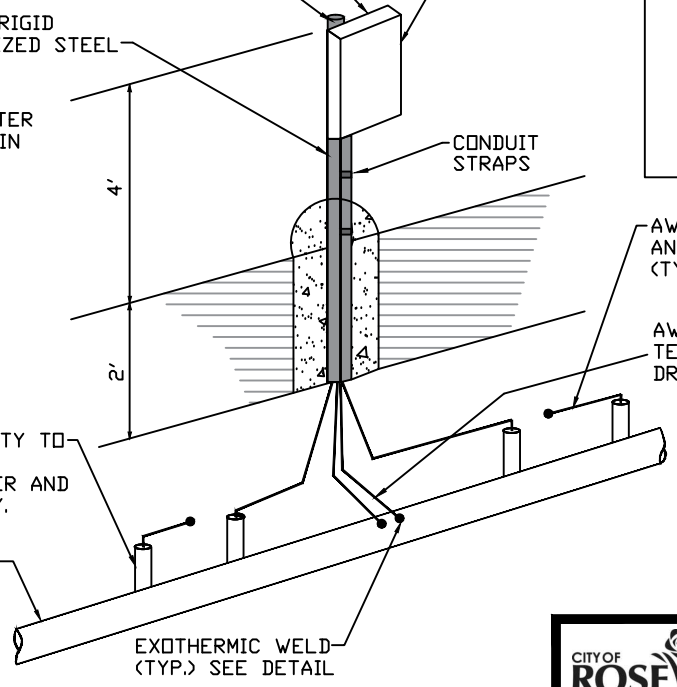

AWG #12 THHN (BLACK) ANODE LEAD CABLE (TYP.)

AWG #10 THHN (WHITE) TEST LEAD AND DRAIN CABLE

Richard D. Plecker

RICHARD PLECKER
ENVIRONMENTAL UTILITIES DIRECTOR



ENVIRONMENTAL UTILITIES DEPARTMENT

GALVANIC ANODE INSTALLATION

SCALE: NONE
REVISED: FEBRUARY 2022
DRAWN BY: J. THOMPSON
APPROVED BY:

W-41

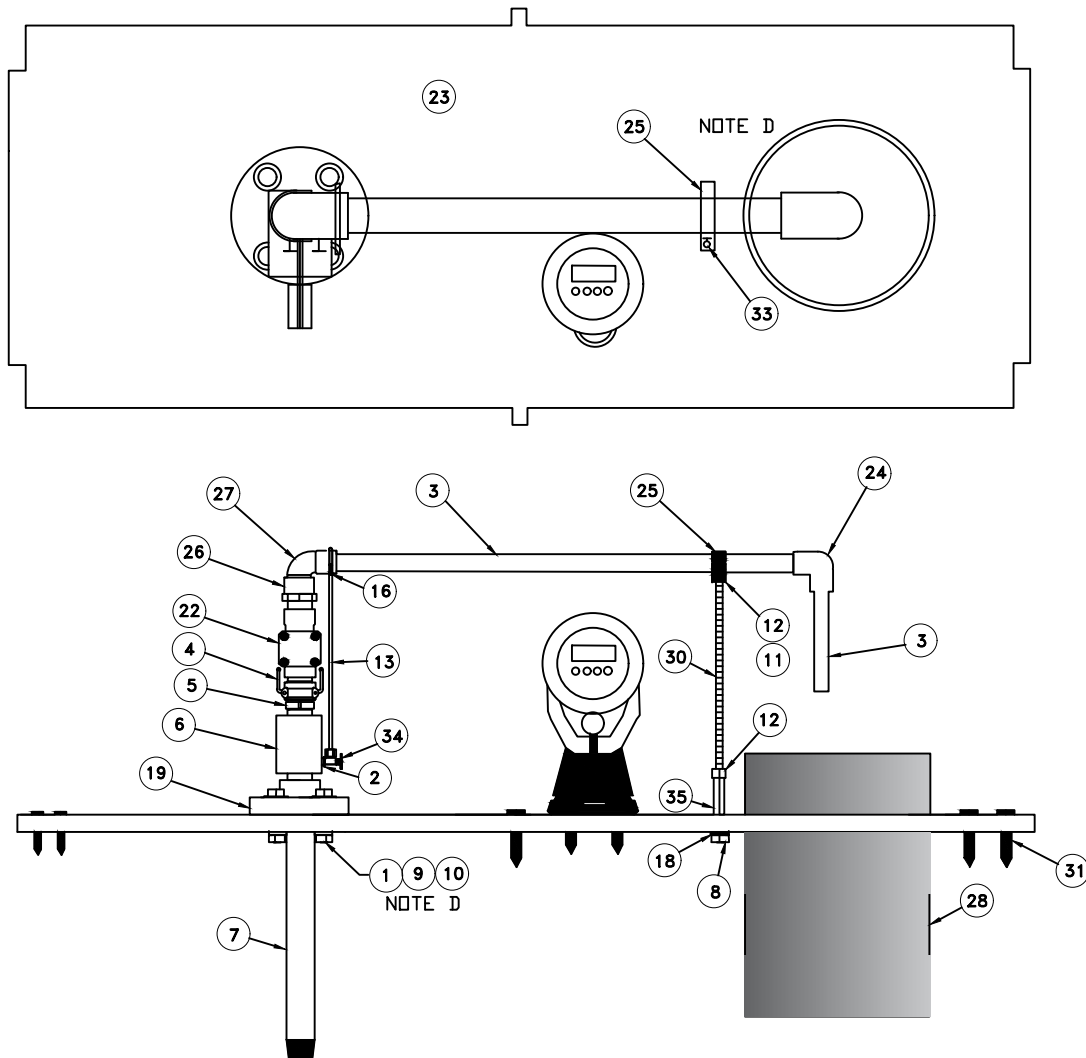

ITEM	DESCRIPTION	NOTES
1	S.S. WASHER FOR THREADED FLANGE	
2	1/4" X 1/8" S.S. HEX BUSHING	
3	1" SCH. 80 PVC PIPE	
4	1" S.S. "B" QUICK DISCONNECT	
5	1" S.S. "F" QUICK DISCONNECT	C
6	1" S.S. COUPLING	
7	1" S.S. PIPE	
8	COUPLING NUT BOLT	
9	S.S. BOLT FOR THREADED FLANGE	
10	S.S. NUT FOR THREADED FLANGE	
11	S.S. LOCK WASHER FOR THREADED FLANGE	
12	3/8"-16 S.S. HEX NUT	
13	1/4" COPPER TUBING	
14	SOLENOID COVER	A,C
15	CONTROLLER COVER	A,C
16	SAMPLING POINT COVER	
18	3/8" S.S. LOCK WASHER	
19	1" SCH. 80 PVC THREADED FLANGE	
20	VALVE CONTROLLER	A
21	9 VOLT BATTERY	A
22	1" PGV VALVE	C
23	9800 WCA FLOOR	
24	1" SCH. 80 PVC ELBOW (GLUE x GLUE)	
25	1" PIPE CLAMP	C
26	1" SCH. 80 PVC ADAPTER (MIP x GLUE)	
27	1" SCH. 80 STREET ELBOW (GLUE x GLUE)	
28	4" SCH. 40 PVC COUPLING	
29	4" SCH. 35 PVC SEWER PIPE	A
30	S.S. THREADED ROD	
31	FLOOR SCREW	
34	90° BRASS NEEDLE VALVE	
35	S.S. COUPLING NUT	

NOTE	DESCRIPTION
A	NOT SHOWN
C	SOLD AS REPLACEMENT PART
D	BOLT ASSEMBLY USED ON ALL SIMILAR HOLES/BRACKETS.

Richard D. Plecker

RICHARD PLECKER
ENVIRONMENTAL UTILITIES DIRECTOR



ENVIRONMENTAL UTILITIES
DEPARTMENT

CHLORINE FLUSHING/ MONITORING STATION

SCALE: NONE
REVISED: JANUARY 2022
DRAWN BY: J. THOMPSON
APPROVED BY:

W-42